

# Operator Manual



**CROWN**



# You Must be Trained



## WARNING

### It's the law, you must be trained and certified to operate this truck.

(OSHA § 1910.178, Rev. 1999)

You or others around you can be seriously injured or even killed if you don't use this truck correctly.

Read and obey all warnings and instructions in this Manual\* and on the truck.

Head, arms, hands, legs or feet outside the operator area can be pinned or crushed whenever the truck is moving. Stay within the operator area and **stop the truck completely before getting off.**

Tipovers and falls from docks can cause serious injury or even death. Grip the steering wheel tightly, brace your feet and lean away from the direction of fall. **Make sure you are safe.**

You can be trapped or crushed by objects protruding or poking into the operator area. **Look where you are going.**

Inspect your truck before starting work, make sure it is in good working order.

\* Additional copies of this Operator Manual and all Truck Labels can be obtained from Crown Equipment Corporation, New Bremen, Ohio 45869 U.S.A.

All rights reserved under International and Pan American copyright conventions  
Copyright 2006 Crown Equipment Corp.



### IT'S THE LAW, YOU MUST BE TRAINED AND CERTIFIED

Federal law states that only properly trained operators are permitted to operate a powered industrial truck and that your employer must train you and certify that you are qualified to operate this powered industrial truck. (OSHA §1910.178, Rev. 1999)

**Do not operate this truck** in your work place until you have been trained and certified by your employer.



**You could be killed or seriously injured** if you are not adequately trained for lift truck operation!

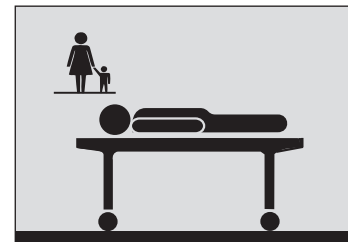

# Protect Yourself

## ! Know the Hazards

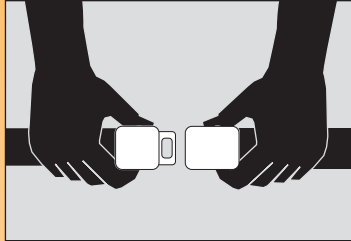

### WEAR YOUR SEAT BELT

Falling from a truck can cause serious injury or even death.

- Fasten your seat belt before operating your truck. Keep it fastened until you leave the truck.
- Stay with your truck. Don't jump from an overturning or falling sit-down rider truck. **Note:** This is not like end-control rider trucks, where it is recommended that the operator exit the truck in these emergencies.

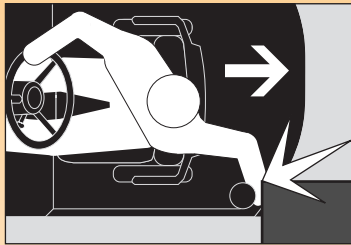

### DRIVE CAREFULLY

- Never stick your foot, hand, head or any part of your body outside the operator area, no matter how slow the truck is moving. Anything caught between the truck and a fixed object will be crushed or even cut off.
- Stay away from the edge of docks and ramps. Make sure dockboards are secure. Check that trailer wheels are chocked. You could be seriously injured or even killed in a fall from a dock or dockboard.
- Keep your truck under control at all times. Drive at a speed that allows you to stop safely. Be even more careful on slippery or uneven surfaces. Do not drive over objects on the floor.



### LOOK WHERE YOU'RE DRIVING

- Always be alert to the area around you and watch where you are driving. You could be pinned or crushed by objects intruding or poking into the operator area.
- Be sure that any equipment added to the truck (terminal, fan, clipboard, etc.) does not block your vision or interfere with safe operation of this truck

## ! Know the Hazards

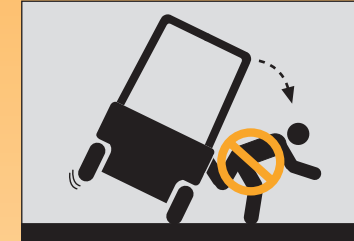

### AVOID FALLS AND TIPOVERS

Tipovers are very serious accidents. You can be crushed or even killed if you try to jump clear of an overturning or falling sit-down truck. Keep your seat belt fastened, grip the steering wheel tightly, brace your feet, and push yourself back between the side restraints. The best way to prevent injury is know where you are at all times and follow the rules of safe truck operation.



- Be extremely careful when working around docks, dockboards and trailers.
- Use forward tilt only when you have the load in a rack, over a stack or close to the floor.
- Travel with the load or forks close to the ground and tilted back. Watch for overhead obstructions. Perform all truck movements smoothly and at a speed that will give you time to react in an emergency.
- An unloaded truck can tip over also. Be just as careful using an unloaded truck as you are a loaded one.

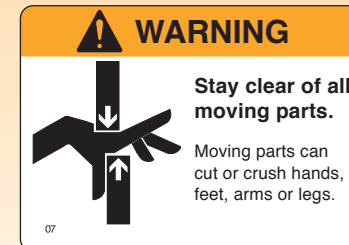

### USE YOUR TRUCK SAFELY

- Keep your hands and feet away from all moving parts such as chains, wheels or mast. Make sure the load backrest is in place, when required.
- Never stand on or under the forks, or allow anyone else to stand on or under them. The only way to lift people is with an approved platform. Never allow passengers on the truck. There is no safe place for them.
- Before you leave your truck: Come to a complete stop, lower forks to the floor, and shut the truck off with the key or power disconnect.

Warning	2
You Must be Trained	3
Protect Yourself	4
Contents	6
What's in it for You?	7
Your Sit-Down Rider	8
Lift Truck Parts	10
Seat	12
Capacity & Load Center	14
Capacity Plate	16
Power On & Off	18
Braking	19
Display	20
Raise/Lower, Tilt & Accessories	22
Traveling & Plugging	24
Optional Armrest & Controls	28
Daily Safety Check	34
Be a Safe Driver	36
Power Sources	40
Charging Power Sources	41
Lithium-ion & Fuel Cell Power Packs	42
Flooded Lead Acid Batteries	44
Warning Labels	46
Notes	47

## WHAT'S IN IT FOR YOU?

The better you understand your truck and how to use it, the better and safer operator you can be. Here are some guides to using this manual.

### Capacity & Load Center

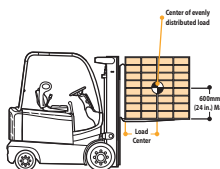

**WHAT IS YOUR TRUCK CAPACITY?**  
Capacity is the load (including pallet or container) that can be lifted to a given height at a given load center. See the capacity plate on your truck. Make certain you use the correct units of measure.

**WHAT IS LOAD CENTER?**  
Load center is the distance from the load backrest or vertical face of the fork to the center of an evenly distributed load.



**LOADS MUST BE EVENLY DISTRIBUTED**  
Your truck could tip over, in any direction, if a load is shifted to the front or side of a pallet or container.

#### Know the Hazards

**SAMPLE CAPACITY PLATE**  
The information shown on this sample plate does not apply to your truck.



**KNOW YOUR LOAD**  
Do not exceed the capacity shown on your truck's capacity plate. Be careful when handling long, high or wide loads. Do not handle unstable loads.

**EXCEEDING TRUCK CAPACITY CAN CAUSE AN ACCIDENT**  
Know the capacity of your truck as shown on your capacity plate. Make certain you use the correct units of measure. Pay attention to:

- Weight of load
- Load center
- Lift height
- Position of mast.

**CENTER THE LOAD**  
Your truck could tip over if a load is shifted to the front or side of a pallet or container. Make sure your load is evenly distributed and centered over the forks.

**HYDRAULIC OPERATIONS CAN AFFECT STABILITY**  
Capacities shown on your capacity plate are with the mast vertical. Be extra careful when tilting a load. (This also applies to other accessories or attachments your truck may have, such as sideshift, push-pull, etc.)

SAMPLE

11 Capacity & Load Center
Capacity & Load

## QUICK LOCATORS

In addition to the "Contents" page you can use page headings to find topics. Some pages also have a picture of the truck in the corner showing features or functions covered on that page.

## "KNOW THE HAZARDS"

Watch for and read these special blocks. You will find information about possible safety hazards and how to avoid them.

## HOW-TO-DRAWINGS

On many pages you will find pictures as well as text to help you understand how to use your truck safely and productively.

# Your Sit-Down Rider



## SIT-DOWN RIDERS

Your sit-down rider truck lifts and stacks loads. It is also designed to move loads over long distances.

## YOUR RIDER TRUCK IS NOT AN AUTOMOBILE

With a load it may weigh more than 4 automobiles, and the steer wheels are in the rear instead of the front.

## FORK FUNCTIONS, STANDARD AND OPTIONAL

Standard fork or hydraulic functions are: Raising and Lowering the forks plus Tilting the mast. Accessories such as Sideshift or Carton Clamp may also be included. Your company has decided which features are needed in your work area and should train you how to use them.

## HOW TO DRIVE YOUR TRUCK

Sit down, fasten your seat belt. Adjust the seat and steering wheel to their most comfortable positions. Keep your hands on the controls and your entire body inside the operator area. Look in the direction you are going.

## GIVE YOUR BODY A BREAK

Take advantage of stop time. Flex your arms and legs. Staying alert will help you be a better and safer driver.

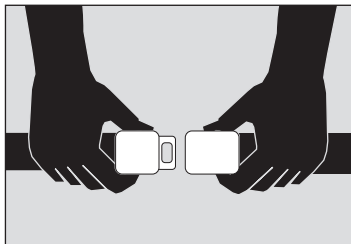

## BUILT TO STANDARDS

This truck was designed and built to current industry and government standards and guidelines. For more information see the following:

- American National Standards Institute (ANSI/ITSDF) B56.1 (Download free from [www.itsdf.org](http://www.itsdf.org))
- Occupational Safety and Health Act (OSHA) §1910.178, Rev. 1999 (Download free from [osha.gov](http://osha.gov))
- Underwriters Laboratory (UL 583)
- National Fire Prevention Association (NFPA 505)

Hands-on controls

Seated

Seat Belt Fastend

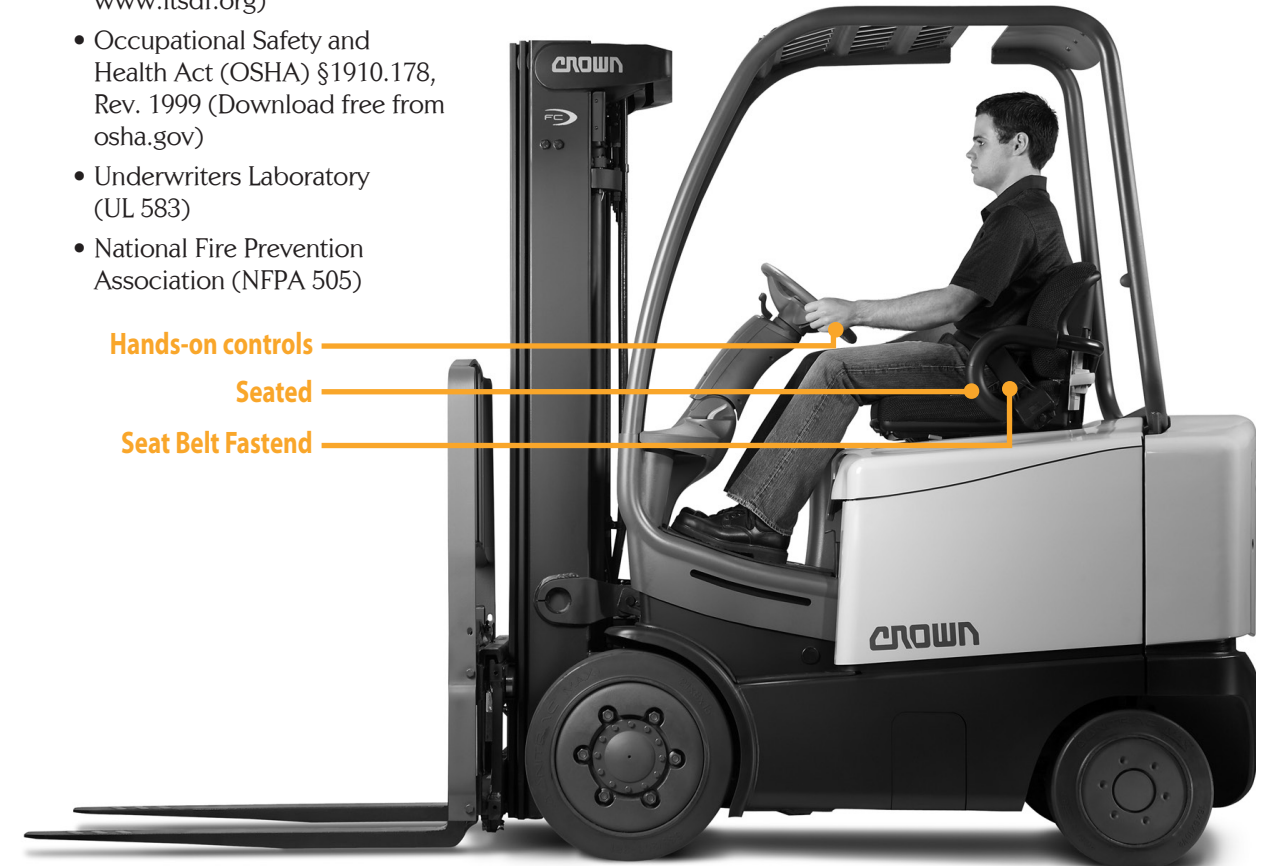

# Lift Truck Parts

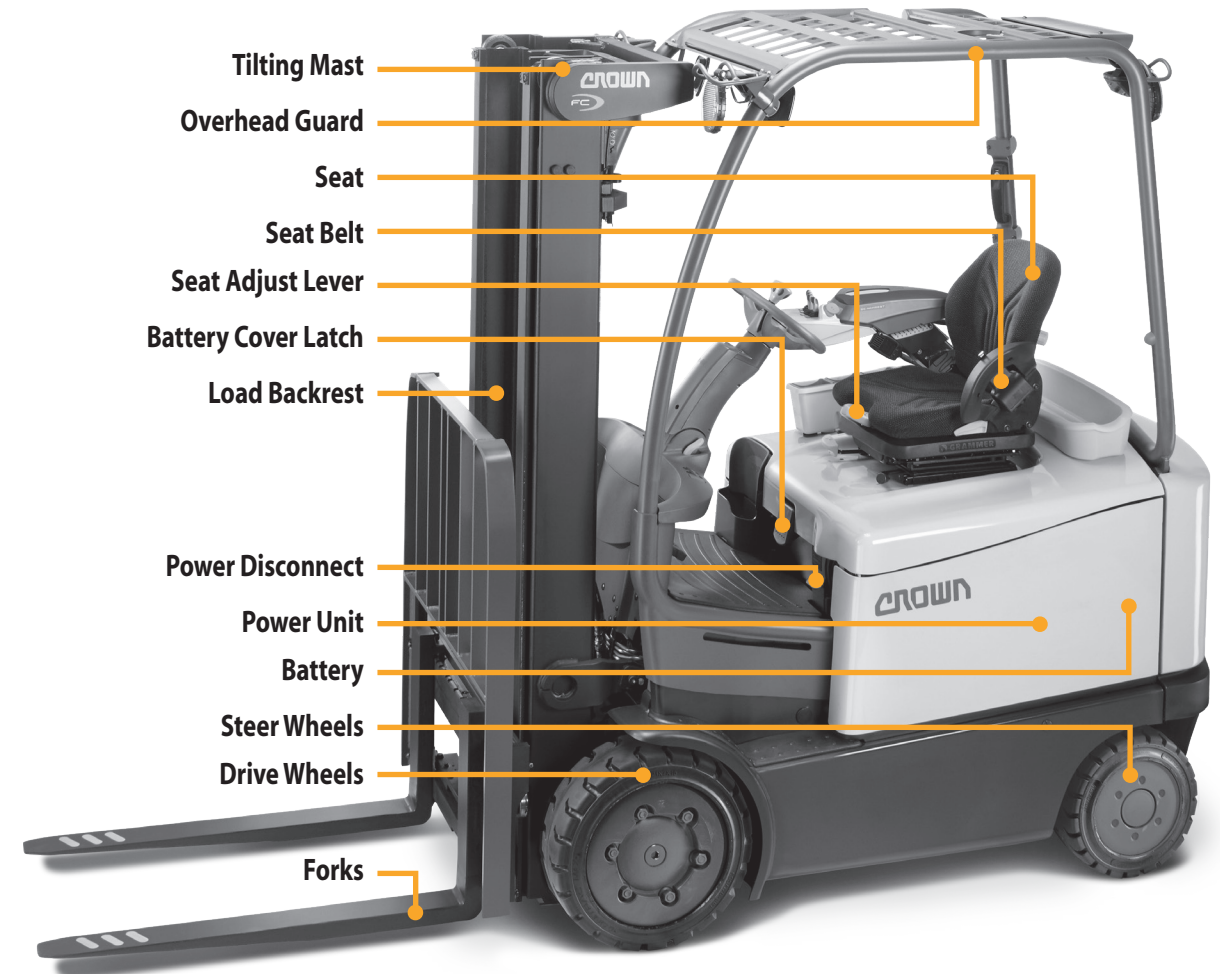
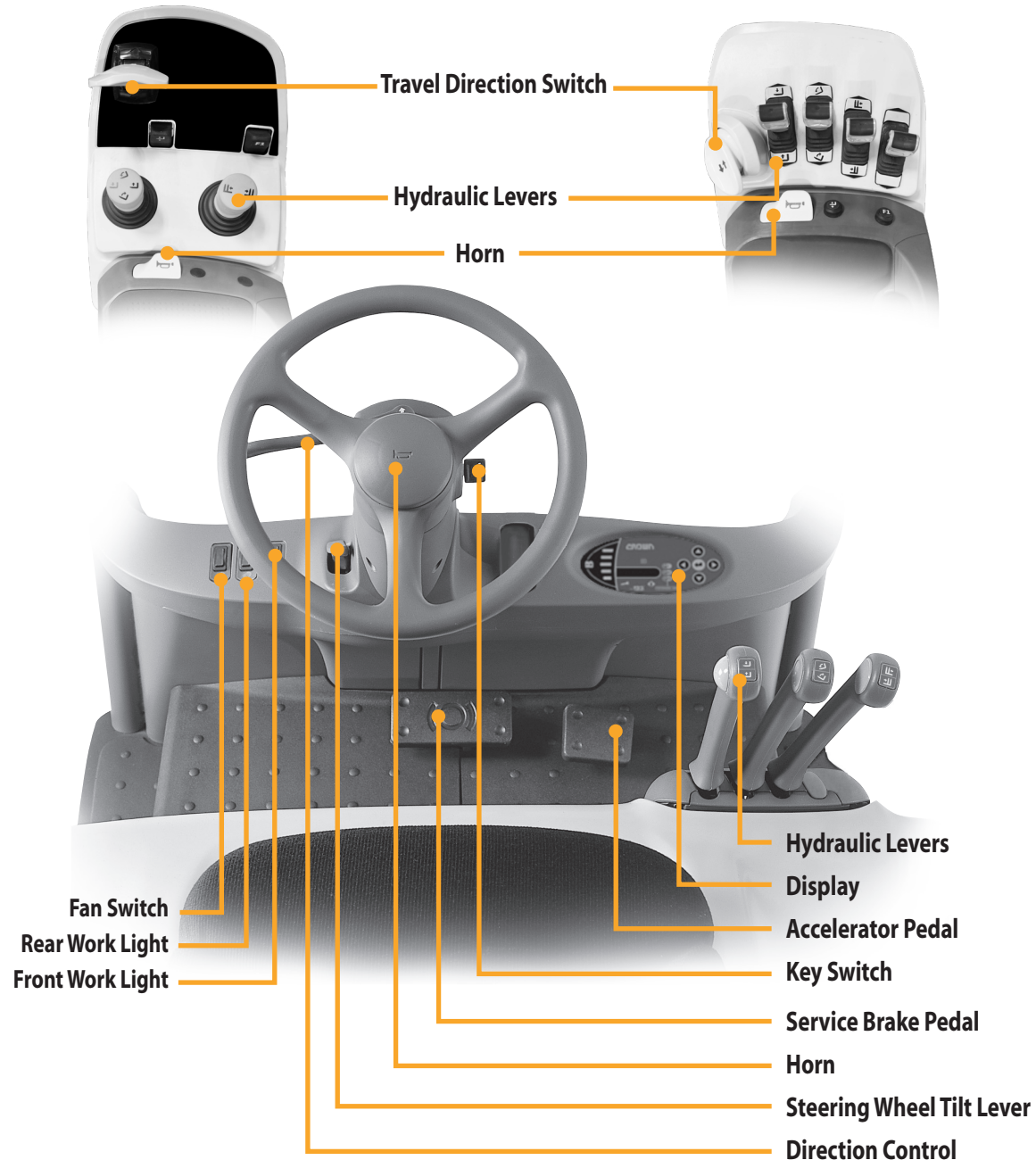

## SEAT

Adjust the seat so you can comfortably reach all the controls. Your truck will have the following seat features:



### ADJUSTING THE SEAT POSITION

To adjust the seat forward or backward, use the lever located in front of the seat.

1. Pull up the lever.
2. Slide the seat forward or backward
3. Release the lever.
4. Move the seat slowly until the seat latches in place.



### ADJUSTING THE BACKREST

To adjust the backrest, use the lever on the side of the seat.

1. Pull up the lever.
2. Lean forward or backward until you reach a comfortable position.
3. Release the lever.

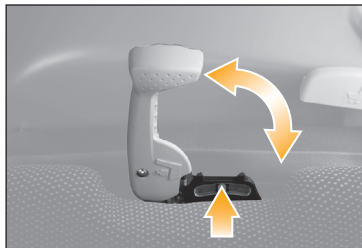

### ADJUSTING THE SUSPENSION

Pull the lever up to increase the suspension. Push the lever down to reduce the suspension.

1. Pull out the lever.
2. Move the lever up or down. Continue to move the lever until the orange indicator appears in the center.
3. Fold in the lever to set the suspension.

This page left  
blank  
intentionally

# Capacity & Load Center



## ! Know the Hazards

**SAMPLE CAPACITY PLATE**  
The information shown on this sample plate does not apply to your truck.

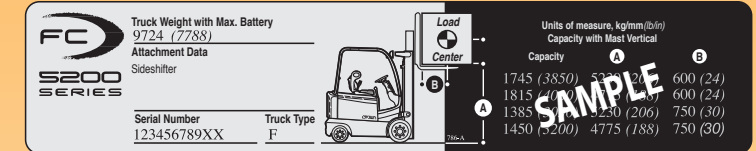

### KNOW YOUR LOAD

Do not exceed the capacity shown on your truck's capacity plate. Be careful when handling long, high or wide loads. Do not handle unstable loads.

### EXCEEDING TRUCK CAPACITY CAN CAUSE AN ACCIDENT

Know the capacity of your truck as shown on your capacity plate. Make certain you use the correct units of measure. Pay attention to:

- Weight of load
- Load center
- Lift height
- Position of mast

### CENTER THE LOAD

Your truck could tip over if a load is shifted to the front or side of a pallet or container. Make sure your load is evenly distributed and centered over the forks.

### HYDRAULIC OPERATIONS CAN AFFECT STABILITY

Capacities shown on your capacity plate are with the mast vertical. Be extra careful when tilting a load. (This also applies to other accessories or attachments your truck may have, such as sideshift, carton clamp, push-pull, etc.)



### WHAT IS YOUR TRUCK CAPACITY?

Capacity is the load (including pallet or container) that can be lifted to a given height at a given load center. See the capacity plate on your truck. Make certain you use the correct units of measure.

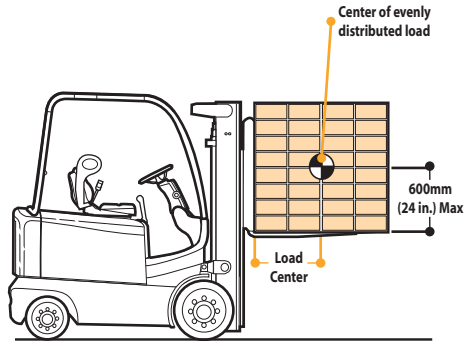

### WHAT IS LOAD CENTER?

Load center is the distance from the load backrest or vertical face of the fork to the center of an evenly distributed load.

### LOADS MUST BE EVENLY DISTRIBUTED

Your truck could tip over, in any direction, if a load is shifted to the front or side of a pallet or container.

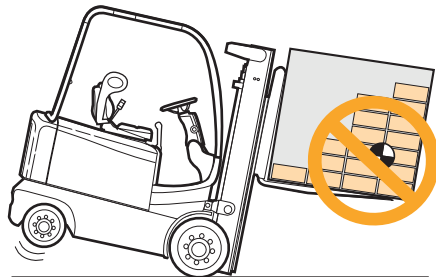

### LOAD POSITION CAN AFFECT STABILITY

Capacities shown on your capacity plate are with the mast vertical and load centered. Be extra careful when tilting a load or using sideshift. (This also applies to other accessories or attachments your truck may have, such as carton clamp, push-pull, etc.)

Make sure your load is centered before you raise, lower, or travel.

The forks should be at least two-thirds (67%) the length of the load. Crown recommends the forks be three-fourths (75%) the length of the load. Make sure the forks do not extend beyond the load.

Use minimum fork tilt to pick up or place a load.

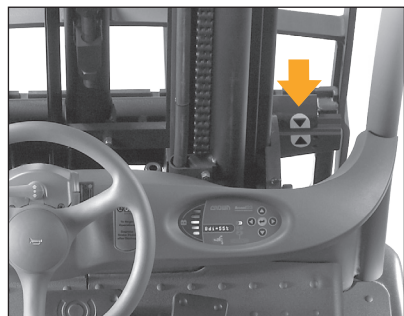



# Capacity Plate



## CAPACITY PLATE INFORMATION

The capacity plate is on the overhead guard. It contains:

- Truck serial number
- Capacity information (load, load center and lift height)
- Truck type (a fire safety rating)
- Truck Weight, Less Load, with Attachments  $\pm$  5%
- Attachment information (if any)

## AFTER AUGUST 2017: READING YOUR CAPACITY PLATE

Capacity may be reduced as lift height **C** increases. For example: On the sample plate, 1815kg (4000 lb) can be lifted to 4775mm (188 in). But above 4775 (188), to 5230 (206), capacity is reduced from 1815 (4000) to 1745 (3850).

Capacity is reduced as load center **A** increases. For example: On the sample plate, 1815kg (4000 lb) can be lifted if the load center is 600mm (24 in). But if the load center is increased to 750mm (30), capacity is reduced from 1815 (4000) to 1450 (3200).

**Caution:** You may not increase capacity if load center is less than shown on your capacity plate.

**Note:** ANSI/ITSDF B56.1 requires that all data be shown first in Metric units and then USA units.

## OTHER LIFT HEIGHTS & LOAD CENTERS

Contact Crown for capacities at lift heights or load centers not given on your capacity plate.

## BEFORE AUGUST 2017: READING YOUR CAPACITY PLATE

Capacity may be reduced as lift height **A** increases. For example: On the sample plate, 1815kg (4000 lb) can be lifted to 4775mm (188 in). But above 4775 (188), to 5230 (206), capacity is reduced from 1815 (4000) to 1745 (3850).

Capacity is reduced as load center **B** increases. For example: On the sample plate, 1815kg (4000 lb) can be lifted if the load center is 600mm (24 in). But if the load center is increased to 750mm (30), capacity is reduced from 1815 (4000) to 1450 (3200).

Units of measure, kg/mm (lb/in)		Capacity with Mast Vertical	
kg (lb)	mm (in)	A	B
1745 (3850)	5230 (206)	600 (24)	600 (24)
1815 (4000)	4775 (188)	600 (24)	600 (24)
1385 (3050)	5230 (206)	750 (30)	750 (30)
1450 (3200)	4775 (188)	750 (30)	750 (30)

**Caution:** You may not increase capacity if load center is less than shown on your capacity plate.

**Note:** ANSI/ITSDF B56.1 requires that all data be shown first in Metric units and then USA units.

**SAMPLE CAPACITY PLATE**  
The information shown on this sample plate does not apply to your truck.

## Know the Hazards

### TRUCK WEIGHT

Dockboards, elevators and some floors have limited capacity. Check your capacity plate for the weight of your truck. Remember to add the weight of the load you have on the forks. Make certain you use the correct units of measure.

### TRUCK TYPE

Some truck types are not permitted in areas where there are fire hazards. Watch for marked areas. For example: You must not drive a type E or ES truck into an area restricted to EE or EX trucks.

### ATTACHMENT DATA

If an attachment on your truck does not match the information given on your capacity plate, don't operate your truck. Your capacity plate may be wrong. Report the problem to your supervisor.

Truck Weight, Less Load, with Max. Battery, and Attachment $\pm$ 5%		Capacity with Mast Vertical		
kg (lb)	mm (in)	A	B	C
1745 (3850)	5230 (206)	600 (24)	600 (24)	600 (24)
1815 (4000)	4775 (188)	600 (24)	600 (24)	600 (24)
1385 (3050)	5230 (206)	750 (30)	750 (30)	750 (30)
1450 (3200)	4775 (188)	750 (30)	750 (30)	750 (30)

Truck Type: **E**

# Power On & Off

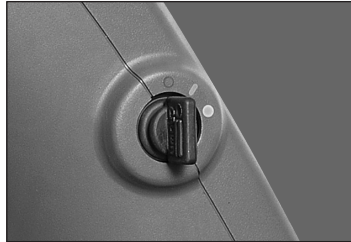

## KEY SWITCH

- Turn the key clockwise to TEST (yellow dot). Make certain the display is working.
- Let go of the key and it will return to ON (green dot).
- Turn key counterclockwise to OFF (red dot) to shut the truck off. Always turn key to OFF when leaving truck.

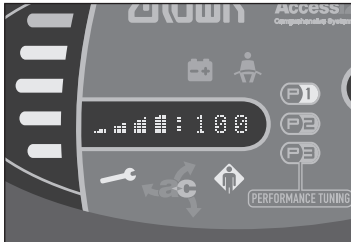

## TO BEGIN TRAVEL AFTER KEY UP:

- Place direction control in neutral.
- Step firmly on the service brake pedal until the display shows "100", then release the pedal.



## POWER DISCONNECT

Pull the Power Disconnect handle up to disconnect the battery and cut power to the truck.

Always use the Power Disconnect if the truck isn't working right. Don't use the truck, and report the problem to your supervisor immediately.

# Braking



## SERVICE BRAKE

Step down on the brake pedal to apply the brakes. The harder you step down, the harder the braking will be.

## PARKING BRAKE

The parking brake is automatically applied after the truck comes to a stop. Avoid parking on inclines. But if you must, block the wheels of your truck.



## Know the Hazards



### MAKE SURE YOUR BRAKES WORK

Test the brakes on your truck at the start of each shift. Know the distance it takes to stop before you start working.

If at any time the stopping distance is too long for you to stop safely, don't drive the truck. Report any problem to your supervisor.

### AVOID PARKING ON INCLINES

Block the wheels of your truck if you must park on an incline.

# Display

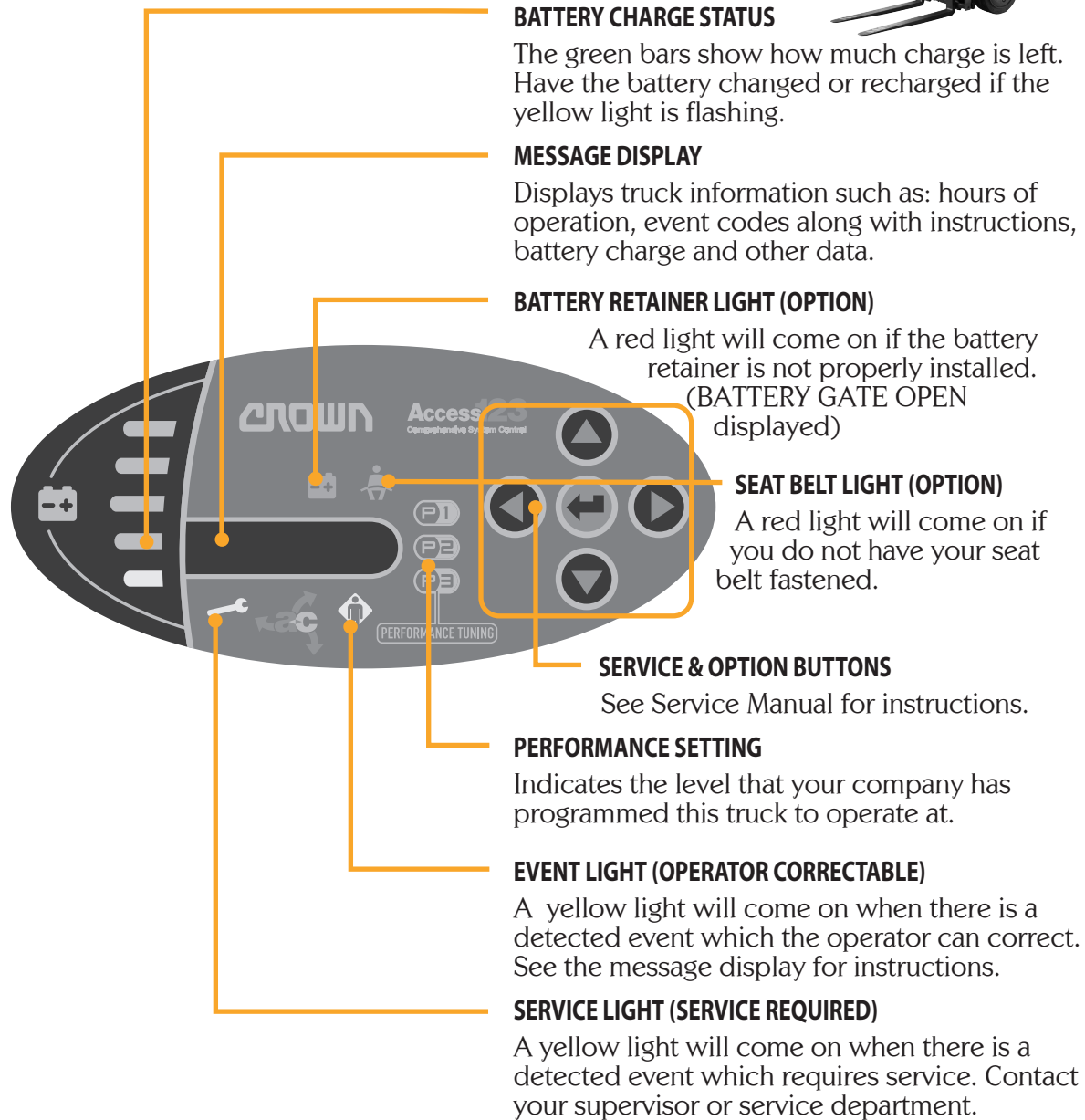

This page left blank intentionally

# Raise/Lower, Tilt & Accessories

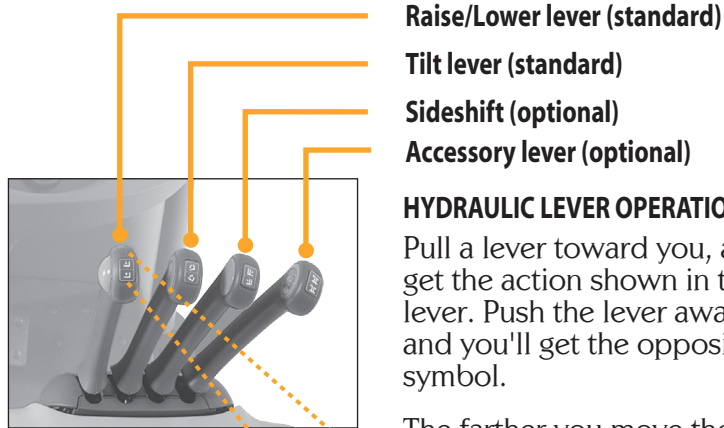

Raise/Lower lever (standard)

Tilt lever (standard)

Sideshift (optional)

Accessory lever (optional)

## HYDRAULIC LEVER OPERATION

Pull a lever toward you, away from the mast, and you'll get the action shown in the bottom symbol on the lever. Push the lever away from you, toward the mast, and you'll get the opposite action shown in the upper symbol.

The farther you move the lever from neutral, the faster the action will be.

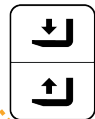

*For example: Pull the Raise/Lower lever toward you to raise the forks, as shown in the bottom symbol.*

*Push the lever away from you to lower the forks.*

**Note:** The left side of each lever has a different shape, to help you identify the lever by feel.



## TILT POSITION ASSIST OPTION



If your truck is equipped with this option, the forks will go to the programmed tilt position chosen by your company for this truck.

To turn on Tilt Position Assist, press the button on the side of the accessory lever. The indicator light will turn on. Pull or push the tilt lever to tilt the forks.

To turn off Tilt Position Assist, press the button on the side of the accessory lever again.



## Know the Hazards

### HYDRAULIC OPERATIONS CAN AFFECT STABILITY

Capacities shown on your capacity plate are with the mast vertical. Be extra careful when tilting a load. (This also applies to other accessories or attachments your truck may have, such as sideshift, carton clamp, push-pull, etc.)

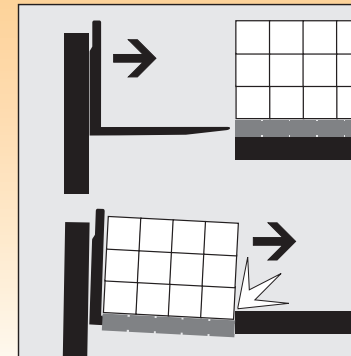

### FORK POSITION WILL VARY DEPENDING ON LOAD

The tilt of the fork tips and raised height of the forks will change depending on how much load is on the forks.

Always check to see that the forks are at the correct tilt position and lift height to enter a pallet, and that the pallet and load will clear the rack beams.



### CHECK THE PATH OF THE FORKS

Make certain the path of the forks is clear and free of obstacles.

Check that the forks are at the proper position to enter the pallet, or that the pallet will clear the rack beam.

# Traveling & Plugging



## BEFORE YOU DRIVE

Adjust the operator seat and steering wheel to a comfortable position. Make sure that you can fully operate the controls.

Fasten your seat belt and pull it snug.

## TO BEGIN TRAVEL AFTER KEY UP:

- Place direction control in neutral.
- Step firmly on the service brake pedal until the display shows “100”, then release the pedal.

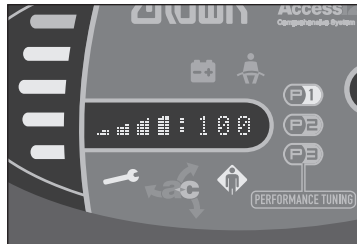

## TRAVEL DIRECTION AND SPEED

Move the direction control lever away from you, toward the mast, to travel forks first. Move the control toward you, away from the mast, to travel power unit first (forks trailing).

Use the accelerator on the floor to control travel speed. The farther you push it down, the faster the truck will go.

If the truck will not move, check the message display.

- RETURN TO NEUTRAL means the direction control must be put in neutral.
- DEPRESS BRAKE PEDAL means the brake pedal must be depressed firmly to release the parking brake.

## OPTIONAL FOOT OPERATED DIRECTION CONTROL

Instead of the hand operated direction control, your employer may have selected a foot operated control. Step on the left side of the pedal to travel forks first, or the right side of the pedal to travel power unit first (forks trailing).

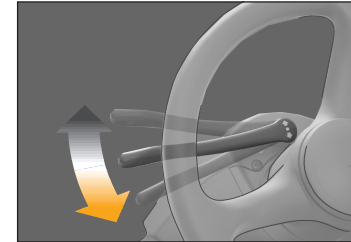

## PLUGGING

Plugging is another way to slow down or stop your truck. While the truck is moving, in either direction, select the opposite direction of travel. Use the accelerator to control how quickly you slow down. Plugging will not stop your truck as fast as using the foot brake.

Plugging does not hurt your truck.

## ! Know the Hazards



### SLOW DOWN FOR SPILLS OR WET FLOORS

Powder or liquid spills can cause slippery floors. Slow down or you could lose control of steering and braking. Be careful and allow for a longer stopping distance.

Don't run over objects on the floor.

### PLUGGING VS. BRAKING

Of the two, the foot brake is designed to stop the truck in the shortest distance. Use the foot brake in an emergency, on ramps or in busy areas.

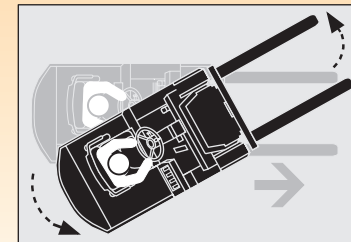

### POWER UNIT SWING

Be careful turning while traveling forks first. The power unit will swing wide in the opposite direction. Make sure you have clearance, and watch out for people in the area.

Slow down when making turns.

# Traveling & Plugging continued



## **HORN**

Press the center of the steering wheel to sound the horn. Use it to warn pedestrians and other drivers.

Use your horn when you leave an aisle or come to a crosswalk or intersection.

This page left  
blank  
intentionally

## **Know the Hazards**

### **LOOK WHERE YOU'RE GOING**

Driver distractions can cause collisions resulting in injury or even death.

- Don't use cell phones or similar devices while operating the truck.
- Travel in the direction that gives you the best visibility.

# Optional Armrest & Controls



## OPTIONAL ARMREST

Adjust the armrest so that you can fully operate the hydraulic levers.

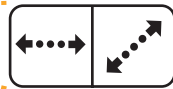

Lift the Raise/Lower lever to pull up or push down the armrest.

Lift the Forward/Back lever to slide the armrest forward or backward.

Make certain the armrest locks into place.

**Note:** Do not make any adjustments while operating the truck.



## TRAVEL DIRECTION AND SPEED

Move the direction control away from you, toward the mast, to travel forks first. Move the control toward you, away from the mast, to travel power unit first (forks trailing).

Use the accelerator on the floor to control travel speed. The farther you push it down, the faster the truck will go.

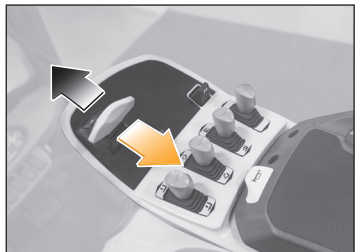

If the truck will not move, check the message display.

- RETURN TO NEUTRAL means the direction control must be put in neutral.
- DEPRESS BRAKE PEDAL means the brake pedal must be depressed firmly to release the parking brake.



## HORN

Sound the horn to warn pedestrians and other drivers. Always use your horn when you leave an aisle or come to a crosswalk or intersection.

## PLUGGING

Plugging is another way to slow down or stop your truck. While the truck is moving, in either direction, select the opposite direction of travel. Use the accelerator to control how quickly you slow down. Plugging will not stop your truck as fast as using the foot brake.

Plugging does not hurt your truck.

*Continued next page...*

# Optional Armrest & Controls

continued

## FOUR STYLES OF CONTROLS

The optional armrest is available with four styles of hydraulic controls, fingertip lever, dual-lever, mini-lever, or combination lever.

## FINGERTIP CONTROL LEVERS



- Raise/Lower (standard)
- Tilt (standard)
- Sideshift (optional)
- Accessory (optional)



## LEVER OPERATION

Pull a lever toward you, away from the mast, and you'll get the action shown in the bottom symbol on the lever. Push the lever away from you, toward the mast, and you'll get the opposite action shown in the upper symbol.

The farther you move the lever from neutral, the faster the action will be.

-  For example: Pull the Raise/Lower lever toward you to raise the forks, as shown in the bottom symbol.
-  Push the lever away from you to lower the forks.



## TILT POSITION ASSIST OPTION

If your truck is equipped with this option, the forks will go to the programmed tilt position chosen by your company for this truck.

To use Tilt Position Assist, press and hold the Tilt Position Assist button. Pull or push the tilt lever to tilt the forks.

## DUAL-LEVER CONTROLS

The left lever controls raise/lower and fork tilt.

The right lever controls an accessory such as sideshift. A fourth function can be added, controlled by forward and back movement.

## LEFT LEVER FUNCTIONS

- 1 Lower forks
- 2 Raise forks
- 3 Tilt forks down
- 4 Tilt forks up

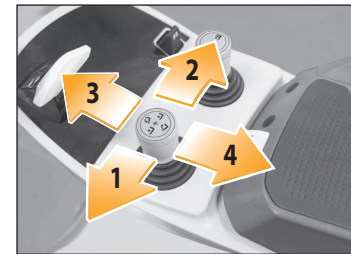

## RIGHT LEVER FUNCTIONS

- 5 Sideshift right (optional)
- 6 Sideshift left (optional)
- 7 Accessory (optional)
- 8 Accessory (optional)



## TILT POSITION ASSIST OPTION

If your truck is equipped with this option, the forks will go to the programmed tilt position chosen by your company for this truck.

To use Tilt Position Assist, press and hold the Tilt Position Assist button. Pull or push the tilt lever to tilt the forks.



Continued next page...



# Optional Armrest & Controls

continued

## MINI-LEVER STYLE

- Raise/Lower (standard)
- Tilt (standard)
- Sideshift (optional)
- Accessory (optional)

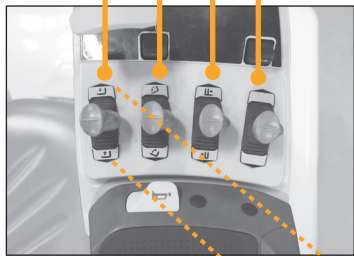

## LEVER OPERATION

Pull a lever toward you, away from the mast, and you'll get the action shown in the bottom symbol on the lever. Push the lever away from you, toward the mast, and you'll get the opposite action shown in the upper symbol.

The farther you move the lever from neutral, the faster the action will be.



*For example: Pull the Raise/Lower lever toward you to raise the forks, as shown in the bottom symbol. Push the lever away from you to lower the forks.*



## TILT POSITION ASSIST OPTION

If your truck is equipped with this option, the forks will go to the programmed tilt position chosen by your company for this truck.

To use Tilt Position Assist, press and hold the Tilt Position Assist button. Pull or push the tilt lever to tilt the forks.

## COMBINATION LEVER

The left lever controls raise/lower and fork tilt.

The right levers control an accessory such as sideshift. A fourth function can be added, controlled by forward and back movement.

## LEFT LEVER FUNCTIONS

- 1 Lower forks
- 2 Raise forks
- 3 Tilt forks down
- 4 Tilt forks up

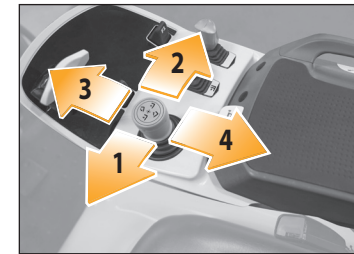

## RIGHT LEVER STYLE

- Sideshift (optional)
- Accessory (optional)

## RIGHT LEVERS FUNCTION

Pull a lever toward you, away from the mast, and you'll get the action shown in the bottom symbol on the lever. Push the lever away from you, toward the mast, and you'll get the opposite action shown in the upper symbol.

The farther you move the lever from neutral, the faster the action will be.



*For example: Pull the lever toward you to sideshift the forks right, as shown in the bottom symbol. Push the lever away from you to sideshift the forks left.*

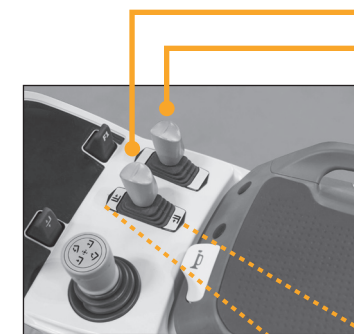

## TILT POSITION ASSIST OPTION

If your truck is equipped with this option, the forks will go to the programmed tilt position chosen by your company for this truck.

To use Tilt Position Assist, press and hold the Tilt Position Assist button. Pull or push the tilt lever to tilt the forks.

# Daily Safety Check



## CHECK YOUR TRUCK BEFORE STARTING WORK

You must make sure your truck is safe to use.

### 1. Walk around your truck and check it over.

- Check to make sure the battery is charged and vent caps are in place. Check water level weekly. Don't use an open flame to check the battery.
- Be certain the battery retainer is properly installed.
- See that all wheels are in good condition.
- Check that both forks are secure and not bent, cracked or badly worn.
- Inspect all lift chains for damage.
- See that the load backrest is in place and secure, when required.
- Look under the truck for signs of leaks.
- Inspect the seat belt for wear.
- Turn the key to ON. Check the display.
- Test the horn.
- Make sure you can read the capacity plate.

### 2. Battery safety check:

- Make certain the gas struts are working properly and will hold the seat deck securely in the open position.
- For flooded lead acid batteries, check battery water level. Don't use an open flame to check the battery. Be sure vent caps are in place.
- Inspect battery cables and connectors for damage or corrosion.

### 3. Test drive your truck in an uncongested area.

- Adjust the operator seat and steering wheel to a comfortable position. Make sure that you can fully operate the controls.
- Fasten your seat belt.
- Try all the hydraulic functions.
- Check that the steering is easy and smooth.
- Drive the truck slowly in both directions.
- Drive through the full speed range in both forward and reverse.
- Check braking and plugging distances in forward and reverse. Load size and floor conditions can affect these distances.
- Know the distance it takes to stop before you start working. If the braking distance is too long to stop safely, don't drive the truck.

**If anything doesn't look or feel right, don't drive the truck. Report the problem to your supervisor.**

*You can get checklist forms from your Crown dealer (part no. OF 3772). Used properly, this checklist can alert service people to needed repairs.*

# Be a Safe Driver

*The most  
important  
component  
is you.*



## MAKE SURE YOU ARE READY TO DRIVE

- Do not use this truck unless you are trained and certified.
- Be certain you understand how your truck works and the hazards that go with it. Don't drive the truck if you have any doubts.
- Know the capacity of your truck (Load Weight, Load Center and Lift Height). Make certain you use the correct units of measure.
- Some trucks are not allowed in areas where there are fire hazards. Be certain your truck is the correct fire safety type for the area.
- Make sure your hands and shoes are clean and dry, and your clothing is proper for the job

## MAKE SURE YOUR TRUCK IS READY

- Inspect your truck before using it (see pages 34 and 35). If it's not working right, or something is broken, report the problem to your supervisor. Don't use the truck.
- Be sure that any equipment added to the truck (terminal, fan, clipboard, etc.) is positioned so that it does not block your vision or interfere with safe and efficient operation of the truck.
- In an open area, test the brakes and plugging. Check at a slow travel speed first, then a faster one. Know the distance it takes to stop before you start work.

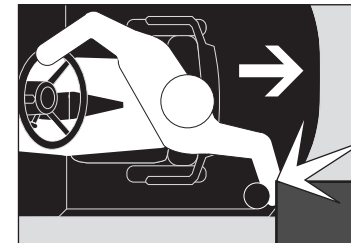
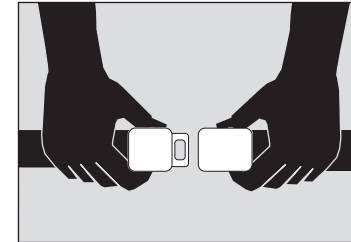

## DRIVE CAUTIOUSLY, BE ALERT

- Adjust the mirror to a position that gives you better visibility.
- Adjust the operator seat, steering wheel, and optional armrest to a comfortable position. Make sure that you can fully operate the controls.
- Adjust the seat and mirror so that you can comfortably reach the controls.
- Fasten your seat belt and pull it snug.
- Never stick an arm or any part of your body outside the operator area, no matter how slow the truck is moving. A hand or foot caught between the truck and a fixed object will be crushed or even cut off.
- Keep your hands on the controls and your feet by the pedals.
- Travel in the direction that gives you the best view. Look where you are going and slow down in congested areas.
- Slow down for wet or slippery floors. Don't run over things.
- Travel with the forks close to the ground and tilted up. Place the load against the load backrest (vertical face of the forks).
- Look where you are going before you change direction of travel.
- See that you have room to drive and turn. Always check for overhead objects.
- Slow down when making turns.
- Avoid sudden movement of controls. Learn to use them smoothly at a moderate, even rate.
- Check clearances before raising or lowering the forks or load.
- Be extra careful if you must use your truck in an area where there is a risk of falling objects.

*Continued next page...*

# Be a Safe Driver continued



## WATCH OUT FOR OTHER PEOPLE

- Slow down. Yield or stop for pedestrians. Use your horn when you come to a crosswalk or intersection.
- Be careful that you don't pin or crush someone. *For example: Never drive your truck toward anyone standing in front of a fixed object.*
- Watch out for power unit swing.
- Never allow passengers on your truck.
- Keep others away from your truck while you're working. Don't ever allow anyone on or under the load or forks.
- Don't let anyone use your truck unless they are trained and certified.
- Never lift anyone with the forks unless they are using an approved platform. Even then, use extreme caution:
  - Use a securely attached and approved safety platform.
  - Make certain lifting mechanism is operating properly.
  - Have mast vertical (never tilt when elevated).
  - Make certain the direction control lever is in neutral.
  - Lift and lower slowly.
  - Watch for overhead obstructions.
  - Be sure you can see and hear the person being lifted.
- Never transport anyone on the platform from one location to another.

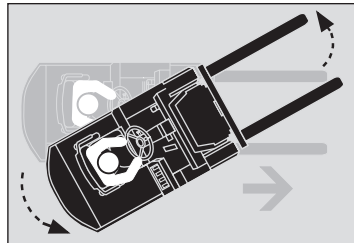

## AVOID FALLS AND TIPOVERS

- Stay with your truck. Don't jump from a moving or falling sit-down truck.
- Stay away from the edge of docks and ramps.
- Check that bridgeplates and dockboards are secure. Be certain that either the trailer wheels are chocked or the trailer is locked to the dock. Check capacities. Be sure your truck, with load, isn't too heavy for where you are driving.
- Make sure the load you are moving is stable. Spread forks as far as you can and center the load. Insert forks as far under the load as you can. Be even more careful with long, high or wide loads. They can be less stable.
- Use forward tilt only when you have the load in a rack, over a stack or close to the floor. Use minimum fork tilt to pick up or place a load. When lifting or lowering outside a rack, keep the mast vertical or tilted back slightly.
- When moving loads on grades or ramps, drive with forks pointed upgrade. Without a load, drive with forks downgrade. Slow down. Don't turn on grades or ramps. Don't raise the mast while on a grade or ramp.

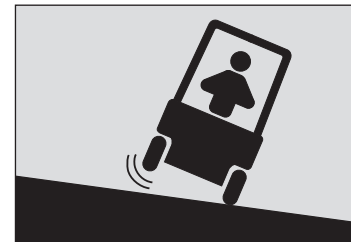

## LEAVING YOUR TRUCK

- Stop your truck completely before getting off.
- Lower the forks to the floor. Turn the truck off or disconnect the battery.
- Avoid parking on inclines. But if you must, block the wheels of your truck.

# Power Sources

## POWER SOURCES

Your truck can be designed to use the following power sources:

- Flooded Lead Acid Batteries
- Thin Plate Pure Lead Acid Batteries
- Lithium-Ion Batteries
- Fuel Cell Power Packs

If your truck is equipped with a V-Force lithium-ion battery, see the data plate installed on your truck.

Only Crown approved power sources are permitted to be used in your truck. Only authorized service personnel are permitted to modify the power source installed in your truck.

See the power source data plate for the approved power source installed in your truck.

**Note:** Follow the manufacturer's specification and instructions when handling power sources.

## WORKING WITH POWER SOURCES

Your company should provide an area that is safe to work on power sources. Use that area for all power source work and charging.

- Do not charge or refuel a power source unless you are trained and authorized.
- Do not remove or install a power source unless you are trained and authorized.

# Charging Power Sources

## BEFORE CHARGING POWER SOURCES

- Read the instructions for the charger and power source.
- Make sure that the charger has the correct voltage and amperage for the power source.
- Only charge a power source in an authorized area.

## CHARGING A FLOODED LEAD ACID BATTERY

1. Turn off your truck.
2. Unplug the power source connector from the truck.
3. Follow the charging instructions from the power source manufacturer.  
When charging is complete, unplug the charger and plug the power source connector into the truck.

## CHARGING A V-FORCE LITHIUM-ION BATTERY

1. Turn off your truck.
2. Plug the charger into the battery charge port.
3. Follow the charging instructions for the V-Force lithium-ion battery.

Opportunity charge during breaks or whenever the truck is not being used.

When opportunity charging is complete or the battery is fully charged, unplug the charger from the battery charge port.



## Know the Hazards

### AVOID DAMAGING THE TRUCK AND BATTERY CHARGER

Make sure that the battery charger is plugged into the battery connector, not the truck connector.

### AVOID DAMAGING THE BATTERY

Batteries that are not properly maintained will fail prematurely.

Always follow the battery manufacturer's instructions.

# Lithium-ion & Fuel Cell Power Packs

## LITHIUM-ION BATTERIES AND FUEL CELL POWER PACKS

For trucks equipped with a V-Force lithium-ion battery, the energy status is shown on the truck display.

Trucks qualified and approved to operate with another lithium-ion battery or fuel cell power pack can have a separate display. Use the display installed on the battery to see the energy status.

This page left  
blank  
intentionally

## Know the Hazards

### AVOID DAMAGING THE POWER SOURCE

Do not leave trucks with lithium-ion batteries or fuel cell power packs in freezing temperatures.

Always follow the battery manufacturer's instructions.

# Flooded Lead Acid Batteries

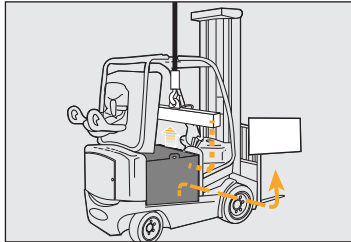

## WHEN YOU INSTALL OR CHANGE A BATTERY

- Turn the truck OFF and check that all controls are in neutral. Disconnect the battery.
- Tilt the steering wheel up, remove the storage tray (if present), and move the seat towards the rear. Raise the seat deck to the open position. **Note:** A seat deck can fall. Make certain the gas struts are working properly and will hold the seat deck securely in the open position.
- Remove the full side cover or short battery retainer.
- Make certain you use the correct size and weight battery. Never operate a truck that has an underweight or undersized battery installed.
- If you use a roller stand to install or remove a battery, make sure the roller stand is the same height as the rollers in your truck's battery compartment. Also make sure the roller stand is at least as long as the battery.
- Never let anything metal touch the top of the cells. You could cause sparks or do damage to the battery. Use an insulator (such as plywood) when necessary.
- Use an approved spreader bar to move a battery to, or from, the battery compartment or stand. Make sure you adjust the spreader bar hooks to fit the battery.

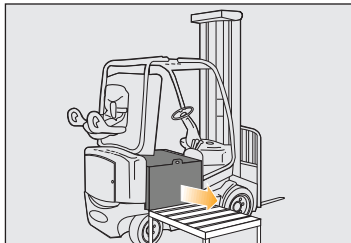

## AFTER INSTALLING YOUR BATTERY

- Replace the battery retainer and side cover.
- Lower and latch the seat deck.
- Connect the battery.
- Return the steering wheel, seat, and optional armrest to a comfortable position. Make sure that you can fully operate the controls. Turn the truck ON and check truck operation.

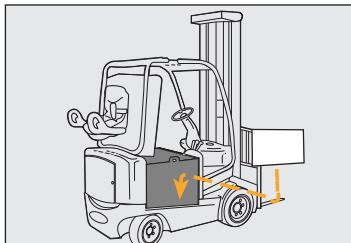

## ! Know the Hazards

**! DANGER**



**Batteries produce explosive gas.**  
Do not smoke, use open flame, or create an arc or sparks near this battery. Ventilate well in enclosed areas and when charging.

Batteries contain **Sulfuric Acid** which causes severe burns. Do not get in eyes, on skin, or clothing. In case of contact, flush immediately. Get medical attention if your eyes are affected.

107

**! WARNING**

**Minimum battery size allowed**  
**000 mm (00.00 in.) wide**  
**000 mm (00.00 in.) long**

Undersize battery can affect truck handling and stability. You could have an accident.  
Use U.L. classified Type EO battery.

## TRUCK BATTERIES CAN BE DANGEROUS

- Your truck battery produces gas that can explode. It also contains acid that could burn or disfigure you.
- Do not try to install, remove, charge or service your truck battery unless you are trained and authorized.
  - Never smoke or use an open flame around batteries.
  - Your company should provide an area where it is safe to work on batteries. Use that area for all battery work.
  - Use protective equipment such as gloves, eye shields, aprons etc. when working on batteries.

## BATTERY RETAINER MUST BE IN PLACE

The battery could slide out if the retainer is not in place. Check that the retainer is installed and secure.

## BATTERY SIZE AND WEIGHT IS IMPORTANT

Make certain you use the correct size and weight battery. Never operate a truck that has an underweight or undersized battery installed.

## BEFORE CHARGING YOUR TRUCK BATTERY

- See that the battery cells are filled to the proper level. Never use an open flame to check the batteries.
- Check that the charger is the same voltage and amperage as the battery. Read the battery charger instructions.
- Be sure the charger is turned OFF before connecting the battery to the charger. Otherwise a spark could cause the battery to explode. Also, make sure the truck key switch is turned off and all controls are in neutral.

# Warning Labels



# Notes

## EACH WARNING LABEL ON YOUR TRUCK IS IMPORTANT

Read and obey all of them to protect yourself and others.

**⚠ DANGER**

**Batteries produce explosive gas.** Do not smoke, use open flame or create an arc or sparks near this battery. Ventilate well in enclosed areas and when charging.

Batteries contain **Sulfuric Acid** which causes severe burns. Do not get in eyes, on skin, or clothing. In case of contact, flush immediately and thoroughly with water. Get medical attention if your eyes are affected.

**⚠ WARNING**

Tilting mast forward when forks are raised and loaded can tip the truck over causing injury or death. **Do not tilt elevated load forward unless it is over a stack.**

<p><b>⚠ WARNING</b></p> <p><b>You can tip this truck over</b> if you turn too sharply for the conditions around you. Don't risk injury or death.</p> <p><b>Slow down when turning.</b></p>	<p><b>⚠ WARNING</b></p> <p><b>Buckle seat belt</b></p>
--	--

**⚠ DANGER**

**In case of tip-over** Follow these instructions:

<b>Don't Jump!</b>	<b>Hold on tight Brace feet</b>	<b>Lean away from tip</b>
--------------------	-------------------------------------	---------------------------

**⚠ WARNING**

**Similar looking trucks can have a different stopping distance.**

Know the distance it takes to stop before you start working.

**⚠ WARNING**

Lifting people without a proper platform could cause a fall or other serious injury. Platform must be built and used as specified in OSHA 1910.178 and ANSI-B56.1.

**⚠ WARNING**

Falling objects or lowering forks can cause serious injury or death. **Never stand under the forks.** While servicing, block the forks so they won't fall.

**⚠ WARNING**

Standing or riding on the forks can cause a fall. You can be seriously injured or killed. **Never stand or ride on forks for any reason.**

**⚠ WARNING**

Passengers could be seriously injured. There is no safe place for them to ride. **No Passengers.**

**⚠ WARNING**

**Stay clear of all moving parts.** Moving parts can cut or crush hands, feet, arms or legs.

**⚠ WARNING**

**It's the law, you must be trained and certified to operate this truck.**

(OSHA § 1910.178, Rev. 1999)

You or people around you could be seriously injured or even killed if you don't use this truck correctly.

Obey all instructions & warnings in the operator manual and on the truck.

**Avoid being crushed.** Keep head, arms, hands, legs, and feet within the operator area. **Stop truck completely before getting off.**

Falls from docks can cause serious injury or even death. **Keep seat belt fastened, hold on, and brace your feet in these emergencies.**

You could be pinned or crushed by objects intruding or poking into the operator area. **Look where you are going.**

Inspect your truck before starting work, make sure it's in good working order.

\* Additional copies of the Operators Manual and Truck Labels can be obtained from: Crown Equipment Corp., [crown.com](http://crown.com)

---

---

---

---

---

---

---

---

---

---

---

---

---

---

---

---

---

---

---

---

---

---

---

---

---

---

---

---

---

---

46 Warning Labels

Notes 47





S200 SERIES

*This operator manual  
has information for  
all models of  
FC5200 series plus  
some options and  
accessories. Some of  
the illustrations and  
information may not  
apply to your truck.*



*The most important component is you.*



New Bremen, Ohio 45869 USA © 2010

600076 B 8/19

Printed in U.S.A.