

CROWN

Operator Manual





Original Instructions

All rights reserved under International and Pan American copyright conventions Copyright 1996-2022 Crown Equipment Corp.



General Information

You Must Be Trained	10
Intended Use of the Truck	11
Manuals for Operation	11
Symbols Overview	12
Text Marking Overview	13
Safety Messages	14
Know the Hazards	16



Your Truck

Your Turret Truck	24
Truck Overview	26
Capacity and Load Center	32
Your Truck Capacity	33
Capacity Plate	34
Reading Your Capacity Plate	36
Capacity Plates for Attachments	37



Truck Operation

Power On and Off	38
Turning On Your Truck Using a Key	38
Turning Off Your Truck Using a Key	38
Turning On Your Truck Using the Display	39
Turning Off Your Truck Using the Display	39
Emergency Disconnect	40
Display Overview	42
Display	46
Widgets	46
Safety Checklist	48
Safety Reminders	49
InfoLink™ Options	50
Equipment Locked	50
2-Way Messaging	51
Impact Detection	52
Dynamic Coaching™	53
Operating Position	54
Harness and Lanyard	54
Operating Position - Seated	56
Operating Position - Standing	57
Hand Sensors	58
Operator Presence Pedal	58
Adjustable Mirror	59
Side Gates	61
Narrow Front Rail Option	61

Continued on next page...



Truck Operation

Seat and Armrest	62
Adjusting the MoveControl Seat	62
Adjusting the Swivel Armrest	63
The Fold-Up Armrest	63
Braking	64
Parking Brake	64
Braking	65
Traveling	66
Travel Direction and Speed	68
Plugging	69
Horn	69
Steering	70
Load Handling	72
Primary Raise and Lower	74
Auxiliary Raise and Lower	75
Traverse	76
Pivot	76
Manual Traverse	77
Load Handling Option	78
Override Function	78
Telescopic Forks	79
Tilt	79



Truck Operation

Additional Options	80
Capacity Data Monitor	84
Pedestrian Detection System	86
Auto Fence System	88
Auto Positioning System	90
Cold Storage Option	92
Cold Storage Cab	94
Entering and Exiting the Cab	94
Exiting the Cab in an Emergency	95
It's Up to You	96
Daily Safety Check	102

Continued on next page...



Power Sources

Power Sources	106
Working with Power Sources	106
Power Source Status	108
Charging Power Sources	110
Charging a Flooded Lead Acid Battery	110
Charging a V-Force™ Lithium-ion Battery	110
Flooded Lead Acid Batteries	112
Removing the Battery	113
Installing the Battery	114



Safety Labels

Safety Labels	116
----------------------	------------



WARNING



You Must Be Trained and Certified

Only properly trained operators are permitted to operate a powered industrial truck.

Your employer must train you and certify that you are qualified to operate this powered industrial truck.
(OSHA §1910.178, Rev. 1999)



You could be killed or seriously injured if you are not adequately trained for lift truck operation!

Do not operate this truck until you have been trained and certified by your employer.

Intended Use of the Truck

Your turret truck is designed to transport, stack, and retrieve loads as well as orderpicking. Use your truck on flat and level floors.

The truck is not authorized for use on public roads.

Manuals for Operation

There are two separate manuals for this truck, the Operator and the Owner Manual. These manuals apply to the following truck models:

- TSP 1000
- TSP 1500

The Operator Manual contains safety and operating instructions, as well as general truck information. It is intended to complement operator training and to be used for future reference.



The Operator is anyone who has been authorized to use this truck. Refer to local, regional, national, or international regulations for operational standards.

The Owner Manual contains Owner responsibility, as well as information needed to maintain, store, or transport the truck.

The Owner is anyone who owns, leases, has been delegated responsibility of, or authorizes the use of the truck to others.

Symbol Overview

The symbol overview explains important elements used in the manual.

Icon	Type	What it means
	Legend Points	Product feature labeling
	Red Impact Marks	Shows personal injury
	Black Impact Marks	Shows product damage

Text Marking Overview

The text marking overview explains important text elements used in the manual.

Text Styling	Type	What it means
<i>Start</i>	Bold Italicized Text	Text as it appears on the screen
<i>For example:</i>	Italicized Text	Examples for further explanation
1. 2.	Work Steps	Steps that must be performed in specific order
▪	Bullet Points	Shows a list

Safety Messages

This operator manual contains important information about your truck and how to use it properly. Safety messages provide instructions on potential hazardous situations, how to avoid them, and the consequences of not avoiding these situations.

Follow all instructions and obey all safety notices in the manuals and on your truck.

Safe truck operation depends on you.

Danger

Indicates a hazardous situation that, if not avoided, will result in death or serious injury.

Warning

Indicates a hazardous situation that, if not avoided, could result in death or serious injury.

 **Caution**

Indicates a hazardous situation that, if not avoided, could result in minor or moderate injury and/or product damage.

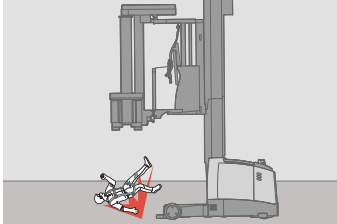

⚠ **Danger**

Falling from a raised platform can cause a serious injury or death.

- Put the gates down and keep your entire body inside the operator compartment.
- Wear your harness and lanyard whenever you are working with an open side gate or a narrow front rail.

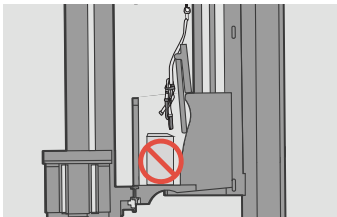

⚠ **Warning**

Keep the operator platform clear

Objects on the platform could trip you and affect truck operation.

Always keep the operator compartment clear.

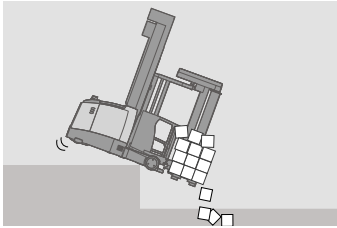

Warning

Avoid falls and tipovers

Falls from docks and tipovers are very serious accidents, you can be crushed or even killed.

- The best way to prevent injury is to know where you are at all times. There is no sure way to avoid injury during a tipover or a drop from a dock.
- Stay away from the edge of docks and ramps.
- When traveling out of the aisle, keep the platform and forks close to the ground.

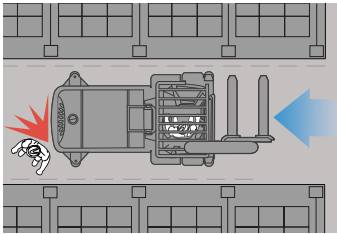

Warning

Stay alert

You must be just as careful using guided travel as you are traveling manually.

- Start slowly and look where you're going.
- Always be prepared to steer manually.
- Make sure your path is clear and nothing is sticking out of a rack.

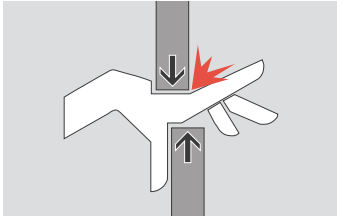

⚠ Warning

Body parts outside of the operator compartment can be crushed or even cut off

- Keep head, arms, hands, legs, and feet within the operator compartment.
- Stop the truck completely before getting off.

Use Your Truck Safely

Do not place yourself or others at risk.

- Keep others away from your truck.
- Never allow passengers on your truck. Do not allow anyone to ride on the load or forks.
- Do not stand underneath or near the forks.



⚠ Warning

Make sure the brakes work

If at any time the stopping distance is too long for you, do not drive your truck.

Notify your supervisor.

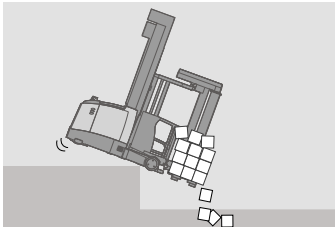
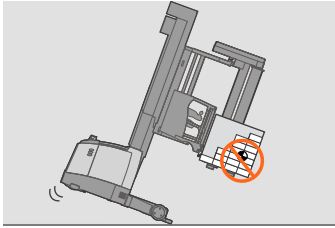

Warning

Avoid tipovers

Loads placed in the front or side of a pallet or container can cause a tipover.

- Know the capacity of your truck. Do not exceed the capacity shown on your truck's capacity plate.
- Make sure that your load is evenly distributed and centered over the forks.
- Make sure the load that you are moving is stable.
- Secure your load. Make sure that your load is resting against the vertical face of the forks or load backrest.
- Do not exceed the maximum load center distance and lift height.

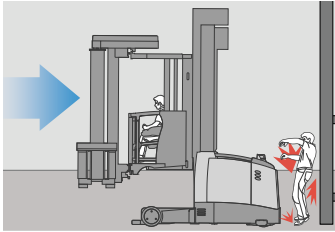

⚠ Warning

Distractions can cause accidents

You or people around you can be seriously injured.

- Always be alert to the area around you and look where you are going.
- You or others could be trapped or crushed by driving into fixed objects.
- Slow down in congested areas.
- Never use cell phones or similar devices while operating your truck.

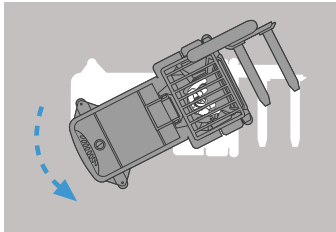

Warning

Prevent impacts with objects or others

The power unit swings wide in the opposite direction when you turn traveling forks first.

- Make sure that you have clearance.
- Keep your hands and feet in the operator compartment.
- Turn carefully and slowly.
- Watch out for people in the area.

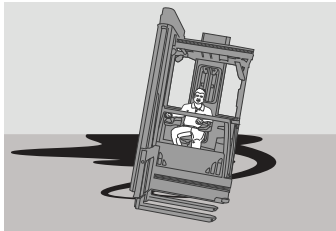

Maintain control of your truck

- Slow down if you see debris or liquid on the floor.
- Do not run over objects on the floor.
- Be careful and prepare for a longer stopping distance.

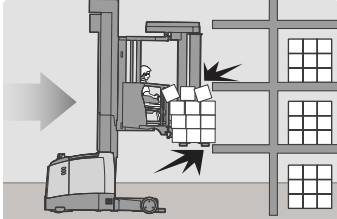

⚠ Warning

Check fork and pallet position

- Be careful when using traverse, pivot, or other operations.
- Before you pivot a load, make sure it won't intrude or poke into the operator compartment.
- Perform all hydraulic operations smoothly.
- Make sure that the forks are at the correct tilt position and lift height to enter a pallet.
- Make sure that the path of the forks and load is clear.



⚠ Warning

Watch out for overhead obstructions

The truck can tip over causing serious injury or even death.

- Be careful traveling near obstructions such as pipes, ducts, doorways, rack tunnels, or low ceilings.
- Be careful when using the override function.

 **Warning****Check the size and type of the battery**

An incorrect battery can affect truck handling and stability causing an accident.

Make sure that you use the correct size, type, and weight of battery.

Check the battery retainer

Unsecured batteries can slide or roll out of the truck.

Make sure that all battery retainers are installed before operating your truck.

 **Warning****Do not rely on automatic feature to control your truck.**

A moving truck can cause serious injury or death. Always come to a complete stop and check for pedestrians before entering an intersection.

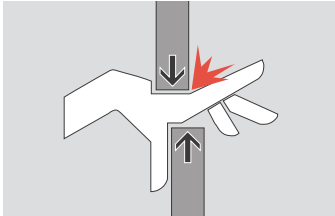

Warning

Body parts outside of the operator compartment can be crushed or even cut off

- Keep head, arms, hands, legs, and feet within the operator compartment.
- Stop the truck completely before getting off.

Use Your Truck Safely

Do not place yourself or others at risk.

- Keep others away from your truck.
- Never allow passengers on your truck. Do not allow anyone to ride on the load or forks.
- Do not stand underneath or near the forks.

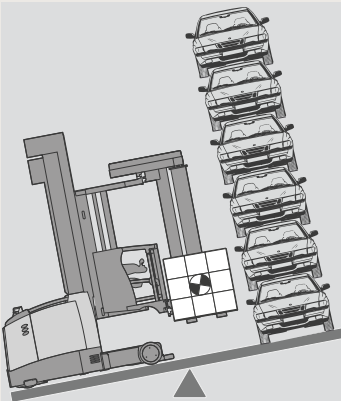

Your Truck Is Not An Automobile

With a load, it may weigh more than six automobiles.

- You don't steer the same.
- You don't brake the same.
- You don't accelerate the same.

Make Sure You Are Ready

- Be certain that you understand how your truck works and the hazards that go with it.
- Make sure that your hands and shoes are clean and dry. Wear clothing that is proper for work.
- Do not operate your truck if you have any doubts.

Make Sure Your Truck Is Ready

Inspect your truck before using it. See **Daily Safety Check** on page 102 for an inspection guide. If your truck is not working correctly or is damaged, do not use it. Notify your supervisor.

Note: Similar looking trucks can be different. Be careful, trucks that look just like yours may not have the same controls, functions, or options.

Watch Out for Other People

- Keep others away from your truck while you're working.
- Never allow passengers on your truck. Do not allow anyone to ride on the load or forks.
- Slow down. Yield or stop for pedestrians.



Turret Truck

- 1 Primary Mast
- 2 Overhead Guard
- 3 Work Lights
- 4 Operator Harness
*See **Harness and Lanyard**
on page 54
- 5 Display
- 6 Load Handler
- 7 Auxiliary Mast



Turret Truck

- 1 Flashing Light
- 2 Lowering Valve
(under rear cover)
- 3 Side Gates
- 4 Battery (inside)
- 5 Load Wheel
- 6 Fork

Continued on next page...



Floor Board

- 1 Foot Brake Pedals

Left Hand Controls

- 2 Steering Handle
 - Display Navigation Knob
 - Override Function
 - Fork Pivot
 - Auxiliary (Fork) Raise/Lower
 - Auto Fork Pivot
 - Left Armrest Swing
 - Integrated Hand Sensor



Floorboard

- 1 Foot Presence Pedal

Right Hand Controls

- 2 Travel
 - Primary (Platform) Raise/Lower
 - Traverse
 - Horn
 - Seat Rotate
 - Seat Height
 - Emergency Disconnect
 - Right Armrest Swing
 - Wire Guidance
 - Integrated Hand Sensor



Switch Panel

- 1 12V Port
- 2 USB Charge Port
- 3 Work Light
- 4 Fan
- 5 Dome Light
- 6 Optional 2nd Work Light



Battery Access

- 1 Battery Connector
- 2 Battery Side Cover
- 3 Battery Retainer (inside)

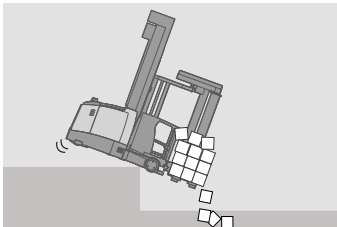
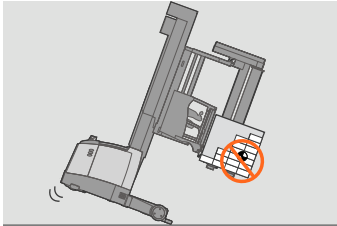

Warning

Avoid tipovers

Loads placed in the front or side of a pallet or container can cause a tipover.

- Know the capacity of your truck. Do not exceed the capacity shown on your truck's capacity plate.
- Make sure that your load is evenly distributed and centered over the forks.
- Make sure the load that you are moving is stable.
- Secure your load. Make sure that your load is resting against the vertical face of the forks or load backrest.
- Do not exceed the maximum load center distance and lift height.

Your Truck Capacity

Capacity is the load, including pallet or container, that can be lifted to a given height at a given load center.

Note: Truck capacity shall be reduced by the operator(s) weight in excess of 100kg (220 lbs). See **Fall Protection / Prevention Selection Chart** on page 55.

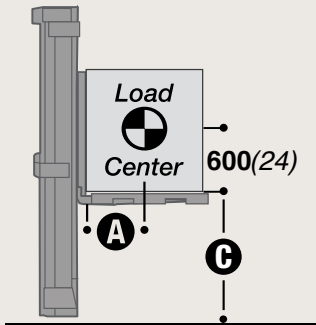

Load Center **A**

The horizontal load center is the distance from the load backrest or vertical face of the forks to the center of an evenly distributed load. See your capacity plate for the load center for your truck.

Note: The load center can differ from the visible center position on the forks.

Lift Height **C**

The height a load can be lifted for the specified capacity.

Anytime the forks move, the load moves. This can affect stability.

Note: Avoid sudden movement of the controls. Learn to use them smoothly at a moderate, even rate.

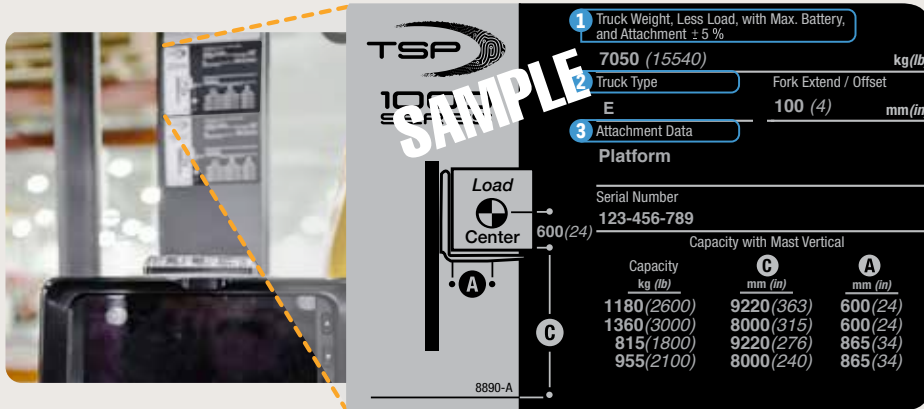

Capacity Plate

Check the capacity plate on your truck. The capacity plate is located on the console of the operator compartment.

The capacity plate contains information such as truck capacity and truck weight without a load. Make sure you use the correct units of measure.

Note: The information shown on this sample capacity plate may not apply to your truck.

1 Truck Weight Less Load with Max. Battery, and Attachment \pm 5%

The weight of your truck without a load. Dock boards, elevators, and some floors can have limits for capacity. Make sure you know the weight of your truck. Remember to add the weight of any load on the forks.

2 Truck Type

Truck type is the fire safety rating for your truck. Watch for marked areas where your truck is not permitted. *For example, you must not operate a type E or ES truck into an area restricted to EE or EX trucks.*

3 Attachment Data

If an attachment on your truck does not match the information on your capacity plate, don't operate your truck. Notify your supervisor.

Continued on next page...

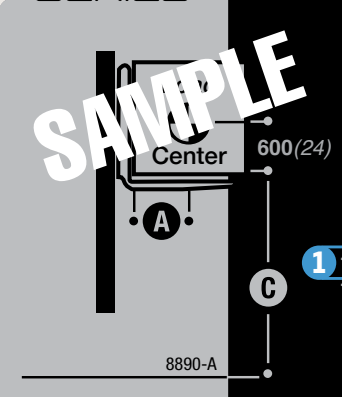

Attachment Data
Platform

Serial Number
123-456-789

Capacity with Mast Vertical

Capacity	C mm (in)	2 A mm (in)
1 1180 (2600)	9220 (363)	600 (24)
1360 (3000)	8000 (315)	600 (24)
815 (1800)	9220 (276)	865 (34)
955 (2100)	8000 (240)	865 (34)

Center 600 (24)

8890-A

Reading Your Capacity Plate

- Capacity may be reduced as lift height **C** increases.
For example: On the sample plate, 1360kg (3000 lb) can be lifted to 8000mm (315 in). But above 8000mm (315 in), to 9220mm (363 in), capacity is reduced from 1360kg (3000 lb) to 1180kg (2600 lb).
- Capacity is reduced as load center **A** increases. If you must handle loads with longer load centers, an additional capacity plate will show the reduced capacities.

Contact Crown for capacities at lift heights or load centers not given on your capacity plate



Capacity Plates for Attachments

There may be additional capacity plates for attachments. Make sure that you look at the capacity plate for the attachment you are using.

The capacity plate and the attachment capacity plate are located above the display of the operator compartment.

Power On and Off

Make sure that the battery is connected. If your truck is not working correctly, notify your supervisor.

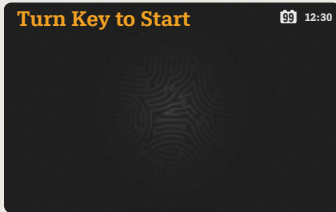

Turning On Your Truck Using a Key

- 1 Off
- 2 On

1. Turn on your truck by turning the key clockwise to **On**.
2. Check that the display is working.

Turning Off Your Truck Using a Key

Turn off your truck by turning the key counterclockwise to **OFF**.

If you turn off your truck and do not log out, the truck will automatically log you out after approximately 10 seconds. **Logging Out (Do Not Travel)** appears on the screen.



Turning On Your Truck Using the Display

You can turn on the truck by one of the following methods:

- Enter your user code
- Pass your ID across the reader
- Press **Start**.

If your ID is recognized, **Welcome** appears on the screen. If **User Not Authorized** appears, notify your supervisor.

Note: While logged in, you are the only user permitted to operate this truck.

Turning Off Your Truck Using the Display

To turn off your truck, log out or pass your ID across the reader. **Logging Out (Do not travel)** appears on the screen.

Note: Depending on your truck settings, completing another inspection can be required. For example, if you log out, and then log in to the same truck during the same shift.

Caution

Prevent unauthorized use

- Always log out before leaving your truck.
- Turn off your truck and remove the key.
- Do not share your user code with others.

Continued on next page...



Emergency Disconnect

Use the emergency disconnect to shut down the truck if it is not working properly. Do not use the emergency disconnect as a brake.

To cut power to the truck, push down the emergency disconnect button. While traveling, the truck will slow to a controlled stop.

To reconnect power to the truck, twist the emergency disconnect clockwise. Restart the truck. See **Power On and Off** on page 38.

Note: Turning off your truck does not cut off all power to your truck. Use the emergency disconnect any time your truck is not working properly. Do not use your truck and notify your supervisor.



Display Overview

Press the touchscreen or push the navigation buttons to see information about your truck. View hours of operation, power source status, and more on the screen.

When using the navigation buttons or display navigation knob, a blue indicator shows your movement on the screen.

Note: While traveling, you cannot interact with the display.



1 Menu or Back

Press the menu or back icon on the screen to view settings and go back to a previous menu.

2 Status Bar

Icons appear at the top of the screen to show the status of the truck.

3 Widgets

Information about your truck such as power source status or date and time are available as widgets.

4 Navigation Buttons

In addition to the touchscreen, you can use the up and down arrows to move through the screen.

5 Enter or Return Button

Use the enter or return button to go backward in menus and confirm selections on the screen.

Continued on next page...

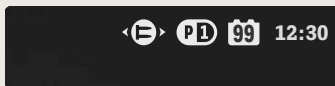

Status Icons

Icons appear in the status bar to show the status of the truck.

Steer Angle Indicator

The travel direction and steer angle of your truck.



Communication Status

Wireless communication is active.



Power Source Status

The energy level of the power source.



Performance Mode

The operating level programmed for your truck.



Parking Brake

The parking brake is applied.



OnTrac™

Traction Control indicator.



Service Required

Notify your supervisor or service department if this icon appears.

Continued on next page...



Widgets

Information about your truck such as the travel direction, battery status, or hours of operation are available as widgets.

The indicators on the bottom of the screen show you the number of widgets that are enabled. Swipe left or right on the screen to change between the widgets.

Press a widget or the enter button to see options available for that widget.

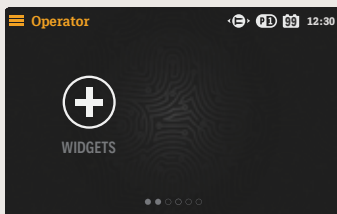

Adding a New Widget

1. Press **+** on the screen.
2. Scroll down to go through the options.
3. Select a widget.
4. Press **Save** to enable the widget.

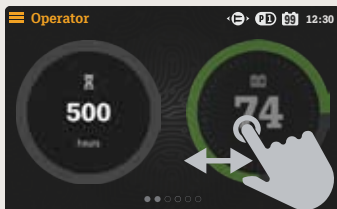

Moving an Existing Widget

1. Press and hold the widget.
2. Drag and drop the widget onto the desired location.

Continued on next page...



Safety Checklist

You are required to conduct an inspection to make sure that the truck is safe to operate. See **Daily Safety Check** on page 102 for an inspection guide. A number of questions can appear on the screen, depending on your company's requirements. Answer all the questions within the time limit shown in the upper right corner.

You may be asked to verify your response by answering the follow-up question ***Are you sure?***

If your response indicates a problem, your truck may be disabled. Do not use your truck and notify your supervisor.

Note: If you are unable to start the inspection checklist, notify your supervisor.

If you need to interrupt the inspection process, press **Cancel** or  in the top left corner of the screen.

During an inspection, the truck will lock for the following situations:

- You allow time to expire twice
- You interrupt an inspection twice
- You allow time to expire and interrupt an inspection
- You answer the truck is not safe to operate during an inspection.

Note: Depending on your truck settings, completing another inspection can be required. For example, if you log out and then log in again to the same truck during the same shift.

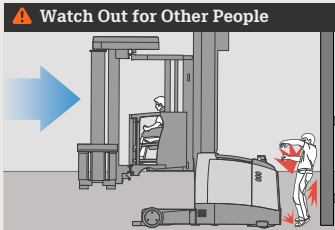

Safety Reminders

Before you can operate the truck, a reminder of safe truck operation will appear on the screen.

Continued on next page...



Equipment Locked

Equipment Locked can appear for various reasons such as impact detection.

You cannot use your truck. If your truck is locked, notify your supervisor.



Emergency Use

In an emergency situation, press 811 on the screen and press the enter button. The screen shows the amount of time in which you can operate the truck. When time expires and the truck is brought to a stop, **Equipment Locked** appears on the screen.



2-Way Messaging

With this feature, your company can send messages to you.

When you receive a message, the icon  appears at the top of the screen with a beep.

When the truck is stationary for 5 seconds, the message appears automatically.

Select one of the pre-programmed responses below the message to answer.

While traveling, an unanswered message disappears. The icon reappears at the top of the screen.



Impact Detection

With the Impact Detection feature, truck impacts are recorded. Depending on your company's settings, your truck can be programmed to only record the event, or record and shutdown the truck.

Impact Detected

When an impact is recorded, **Impact Detected** appears on the screen. After a short time this will disappear. Notify your supervisor.



Impact Shutdown

You can operate the truck for a short distance and time. When **Logging Out (Do not travel)** appears on the screen, you will be logged out within the time shown. The truck will shutdown and lock. **Equipment Locked** appears on the screen.

You cannot use your truck. If your truck is locked, notify your supervisor.



If strobe lights and audible alarms are installed for impact detection, they will illuminate and sound after an impact.



Dynamic Coaching™

The Dynamic Coaching feature provides audible and visual feedback on how you operate the truck. Your truck can show alert messages to reinforce safe operation.

Red Screens

Alerts of incorrect operation.

- **Impact Detected** (screen may show countdown to lockout)



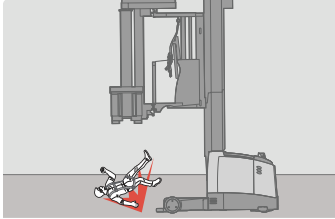

Danger

Falling from a raised platform can cause a serious injury or death.

- Put the gates down and keep your entire body inside the operator compartment.
- Wear your harness and lanyard whenever you are working with an open side gate or a narrow front rail.



Harness and Lanyard

Use your harness and lanyard whenever you are working from a raised platform and have a side gate open. Make sure to attach the lanyard to your harness and to the truck.

Note: Trucks equipped with the narrow front rail option have only a right side gate. The harness and lanyard must be worn at all times.

Check the harness, lanyard, snap hooks, and mounting points daily for wear or damage. Follow the manufacturers instructions for proper fit, inspection, and maintenance.

Note: If something is not working correctly or is damaged, do not use it. Notify your supervisor.

Fall Protection / Prevention Selection Chart

Fall Protection Devices	Operator Weight ³ kg (lbs.)			
	< 141 kg ¹ (<311 lbs.) ¹	141-181 kg ¹ (311 - 400 lbs.) ¹	>181 kg ¹ (>400 lbs.) ¹	
Full Body Harness	X	X	X	Contact Crown
Energy Absorber - max total length 1.8m (6ft)	X ²			
Self-Retracting Lanyard - max total length 2.4m (8ft)		X	X	

1. **Truck capacity shall be reduced by the operator(s) weight in excess of 100kg (220lbs).**
2. Energy Absorbing Lanyard is prohibited by CAL-OSHA in the state of California.
3. All components of the fall protection system shall be rated for the operator's weight.

Note: Pregnant women must not use fall protection devices.

Continued on next page...

Sit and Stand Option

You can drive while seated, with the seat in one of four locked positions. Or, with the seat locked in the straight ahead position, flip the seat up to drive while standing. Braking and foot presence pedal operation are not the same for the two operating positions.

Operating Position - Seated

You can operate your truck seated or standing.

- 1 Side gates down
- 2 Hands on controls
- 3 Feet on the brake pedals

You can adjust the seat and the armrest. See **Seat and Armrest** on page 62. Make sure you can comfortably reach the controls.

Note: Do not make any adjustments while the truck is moving

Before you can operate your truck, you must cycle the controls.

1. Press and release either brake pedal.
2. Slowly move the right multi-task control handle and return it to neutral.

The truck is ready for operation.





Operating Position - Standing

You can operate your truck seated or standing. Flip up the seat to drive while standing.

- 1 Hands on controls
- 2 Side gates down
- 3 Feet on the presence pedals

You can adjust the height of the armrest. See **Seat and Armrest** on page 62. Make sure you can comfortably reach the controls.

Note: Do not make any adjustments while the truck is moving.

Before you can operate your truck, you must cycle the controls.

1. Press and release either brake pedal.
2. Slowly move the right multi-task control handle and return it to neutral.

The truck is ready for operation.

Continued on next page...



Hand Sensors

You must have a hand on each of the multi-task controls for the following load handling functions:

- To initiate platform lift
- Auxiliary raise or lower
- Traverse & extend/retract
- Pivot (manual & auto)

You must have a hand on the right multi-task control for the following to operate:

- Travel
- Platform raise or lower

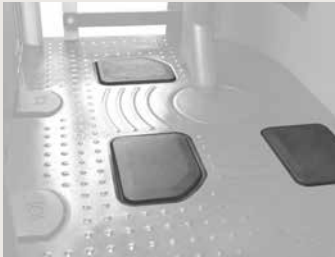

Operator Presence Pedal

Whether sitting or standing, you must have your feet on two of the three foot presence pedals to operate the truck. If any truck functions don't work, your hands or feet may be out of position. Check the display for instructions.

You can adjust your feet for posture relief.

- While seated, if you remove a foot from one of the presence pedals, the truck will slow to a stop.
- While standing, if you remove a foot from one of the presence pedals, the brake is applied.



Adjustable Mirror

Adjust the mirror to a position that allows you to see along the side of the truck and into the aisle behind you. Use the mirror only while maneuvering.

When adjusting the mirror, keep in mind all operating positions.

Continued on next page...

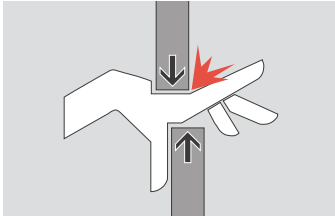

! Warning

Body parts outside of the operator compartment can be crushed or even cut off

- Keep head, arms, hands, legs, and feet within the operator compartment.
- Stop the truck completely before getting off.

Use Your Truck Safely

Do not place yourself or others at risk.

- Keep others away from your truck.
- Never allow passengers on your truck. Do not allow anyone to ride on the load or forks.
- Do not stand underneath or near the forks.

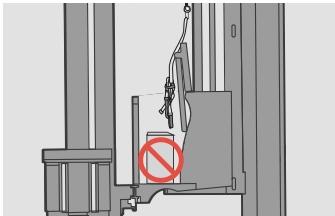

Keep the operator platform clear

Objects on the platform could trip you and affect truck operation.

Always keep the operator compartment clear.



Side Gates

Use your harness and lanyard whenever you are working from a raised platform and have a side gate open.

Use the handle to open and close the side gates. To operate the truck keep the gates down.

- Don't sit or climb on the gates.
- Keep your entire body within the operator compartment.



Narrow Front Rail Option

Trucks equipped with the narrow front rail option have only a right side gate.

The harness and lanyard must be worn at all times.

Seat and Armrest

Your operator compartment can have the following adjustable features:

Adjusting the MoveControl Seat

Press the trigger on the front of the right multi-task handle to rotate the seat. Make sure it locks in one of the four positions.

The side facing seat position gives you the best view for driving power unit first. A faster travel speed is also available with the seat in this position.



Adjusting the seat height

Pull the release lever under the right armrest to move the seat up or down.



Adjusting the Swivel Armrest

Adjusting the armrest can also make it easier to get on or off the truck. Press the button on the inside of the armrest to release and swing the armrest.



The Fold-Up Armrest

Pull the release lever under the left armrest to fold up the armrest.



Warning

Make sure the brakes work

If at any time the stopping distance is too long for you, do not drive your truck.

Notify your supervisor.



Parking Brake

When the parking brake is applied, the parking brake symbol is shown in the status bar.

The parking brake is automatically applied after the truck comes to a stop.



Braking

Before you start working, test the brake.

In an open area, first check braking at a slow travel speed and then at a faster one.

Applying the Brake while seated

To apply the brake, step down on either of the front pedals.

When in the seated position, the truck will coast if you remove either foot from a presence pedal.

Note: Braking is designed to stop your truck in the shortest distance. Use the brake in an emergency or in busy areas.



Applying the Brake while standing

To apply the brake in the standing position, lift your foot from either presence pedal.

Caution

Braking seated vs standing

The presence pedal does not work the same seated as it does standing. Make sure you understand how to stop your truck in all operating positions.

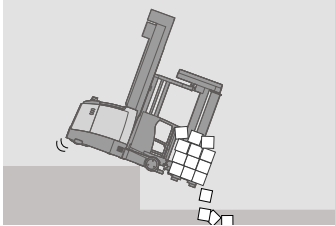

! Warning

Avoid falls and tipovers

Falls from docks and tipovers are very serious accidents, you can be crushed or even killed.

- The best way to prevent injury is to know where you are at all times. There is no sure way to avoid injury during a tipover or a drop from a dock.
- Stay away from the edge of docks and ramps.
- When traveling out of the aisle, keep the platform and forks close to the ground.

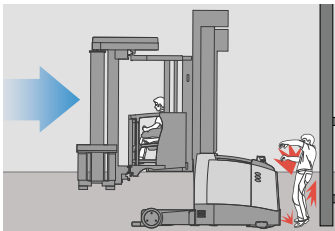

Distractions can cause accidents

You or people around you can be seriously injured.

- Always be alert to the area around you and look where you are going.
- You or others could be trapped or crushed by driving into fixed objects.
- Slow down in congested areas.
- Never use cell phones or similar devices while operating your truck.



Traveling

Travel in the direction that gives you the best visibility. Make sure that there is clearance for your entire truck.

Your truck has the following traveling directions:

- Power Unit First
- Forks First

The icon  appears in the status bar. Depending on your selected widgets, the screen can show your travel direction or steer angle.

Note: An unloaded truck can tip over as well. Be just as careful using an unloaded truck as you are using one that is loaded.

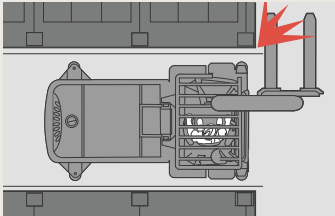

Before traveling, you must pivot the forks and traverse the load handler so the forks or the load do not extend past the sides of the truck. When outside the aisle, travel with the forks close to the floor.

While traveling, you cannot interact with the display.



Before you leave your truck, come to a complete stop and lower the forks. Turn off the truck using the display or key.

Continued on next page...

Travel Direction and Speed

Use the right multi-task control handle to control travel direction and speed. Travel at a speed that allows you to stop safely.

Note: Avoid sudden movement of the controls. Learn to use them smoothly at a moderate, even rate.



Traveling Power Unit First

To travel power unit first, pull the right multi-task control handle toward you.

The farther you pull the handle from the neutral position, the faster the truck will travel.



Traveling Fork First

To travel forks first, push the right multi-task control handle away from you.

The farther you push the handle from the neutral position, the faster the truck will travel.



Plugging

Plugging is another way to slow down or stop your truck. While the truck is moving in either direction, move the multi-task control handle in the opposite travel direction.

Note: Braking vs. Plugging

Of the two, braking is designed to stop your truck in the shortest distance. Use the brake in an emergency or in busy areas.



Horn

Push the button on the right multi-task control handle to sound the horn. Warn pedestrians and other operators that you are nearby. Use the horn in areas such as intersections or crosswalks.

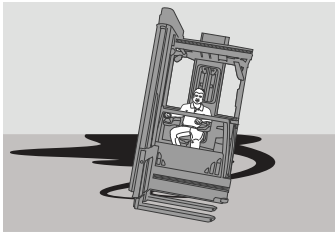
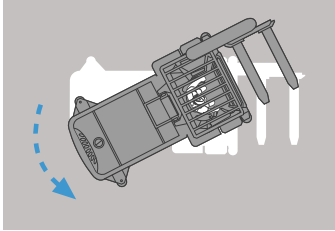

! Warning

Prevent impacts with objects or others

The power unit swings wide in the opposite direction when you turn traveling forks first.

- Make sure that you have clearance.
- Keep your hands and feet in the operator compartment.
- Turn carefully and slowly.
- Watch out for people in the area.

Maintain control of your truck

- Slow down if you see debris or liquid on the floor.
- Do not run over objects on the floor.
- Be careful and prepare for a longer stopping distance.

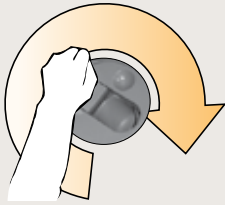

Steering

To control steering, rotate the steering handle. Your truck is designed to slow down when turning.

An icon  in the status bar and the steering widget show your travel direction and steer angle.

Note: Be careful. Avoid sudden changes in direction. Drive slowly until you get used to all the controls.

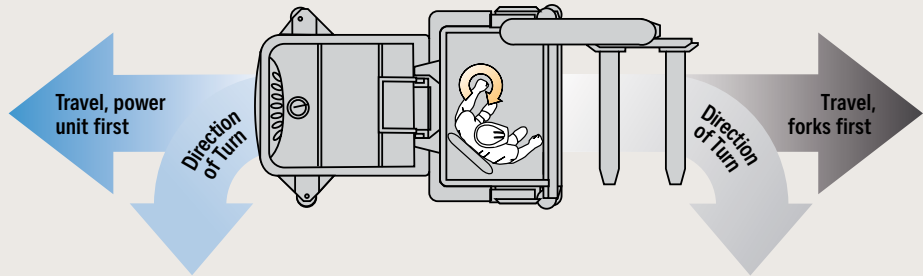

This shows the direction your truck will turn, when you turn the steering handle clockwise.

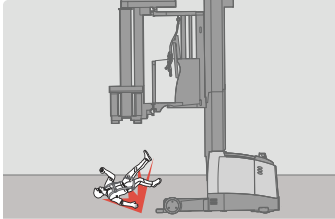

! Danger

Falling from a raised platform can cause a serious injury or death.

- Put the gates down and keep your entire body inside the operator compartment.
- Wear your harness and lanyard whenever you are working with an open side gate or a narrow front rail.

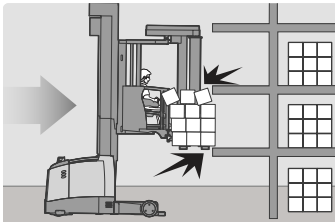

! Warning

Check fork and pallet position

- Be careful when using traverse, pivot, or other operations.
- Before you pivot a load, make sure it won't intrude or poke into the operator compartment.
- Perform all hydraulic operations smoothly.
- Make sure that the forks are at the correct tilt position and lift height to enter a pallet.
- Make sure that the path of the forks and load is clear.

Load Handling

Your truck is equipped with standard fork functions raise, lower, traverse, and pivot. It can also have extend and tilt.

Make sure that your load is evenly distributed, stable, and centered over the forks.

The forks should be at least two-thirds (67%) the length of the load. Crown recommends the forks be three-fourths (75%) the length of the load. Make sure the forks do not extend beyond the load.

Use minimum fork tilt to pick up or place a load.

Be careful moving a wide or tall load. Make sure you or someone around you does not get pinned or crushed.

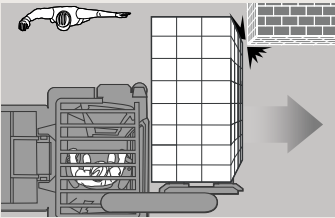

Continued on next page...

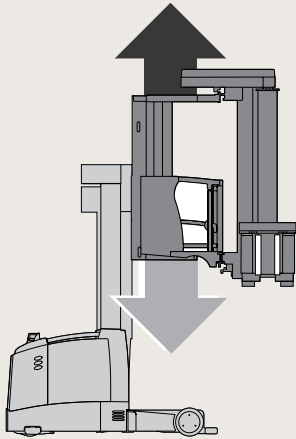

Primary Raise and Lower

Primary raise and lower lets you move the entire operator platform and forks, up or down on the primary mast.

Move the right multi-task control handle to the right to raise and to the left to lower the platform and forks.

Note: The farther you move the multi-task control handle from neutral, the faster the platform will move.



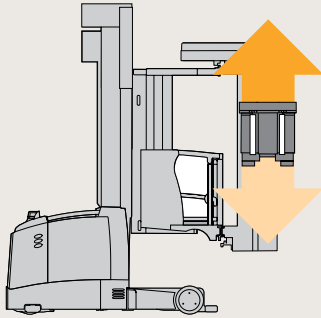

Auxiliary Raise and Lower

Auxiliary raise and lower lets you move just the forks up or down on the auxiliary mast.

To move just the forks, roll the left thumb ball up to raise and roll down to lower the forks.

Note: The farther you move the thumb ball from neutral, the faster the forks will move.



Manual Lowering

If there is a problem with primary lowering, you can have someone on the floor lower the platform by using the manual lowering valve. The valve is located under the rear power unit cover, on the right side of the truck.

Before lowering, make sure the forks, load, and platform are free from obstructions. Traverse the forks clear of the rack. See **Manual Traverse** on page 77.

Note: Always be alert for an on-screen message or any other indications that the lift chains have become slack. A slack chain condition can cause serious injury by allowing the platform to drop suddenly.

Immediately alert the person on the floor of a slack chain condition. Stop lowering and raise carefully.

Continued on next page...

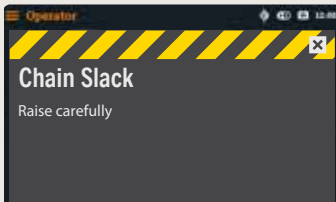

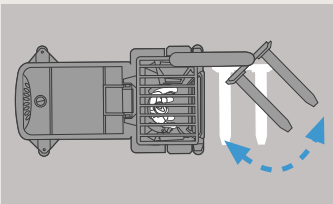
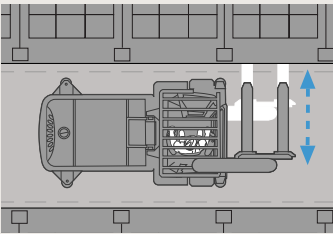

Traverse

Before you traverse a load, make sure it will clear the platform.

Right Multi-task Control Handle

- 1 Traverse Left ←
- 2 Traverse Right →

Move the thumb ball away from you to traverse left and toward you to traverse right.

Note: The farther you move the thumb ball from neutral, the faster the load handler will move.

Pivot

Before you pivot a load, make sure it will not poke or intrude into the operator compartment.

Left Multi-task Control Handle

- 1 Pivot Left ↻
- 2 Pivot Right ↻

Push the thumb ball away from you to pivot the forks clockwise. Push the ball towards you to pivot the forks counter clockwise.



Auto Pivot

This feature allows you to traverse and pivot at the same time, keeping the forks within the running lines of the truck.

Press the trigger on the front of the left multi-task handle. Then roll the traverse thumb ball in the direction you want the forks to traverse. The forks will traverse and pivot automatically.

Manual Traverse

If there is a problem with traverse, you can have someone on the floor assist you by using the power unit manual traverse switch. The switch is located under the rear power unit cover, on the right side of the truck.

To traverse out of the rack

Locate the platform manual traverse switch in the left hand storage area.

Press this switch while your assistant on the floor is pressing the power unit switch. The forks will traverse out of the rack. Either of you can stop the movement by releasing your switch.

To traverse into the rack

Press the platform switch twice to traverse into the rack.



Warning

Watch out for overhead obstructions

The truck can tip over causing serious injury or even death.

- Be careful traveling near obstructions such as pipes, ducts, doorways, rack tunnels, or low ceilings.
- Be careful when using the override function.

Override Function

Your truck can be programmed to stop raising in areas with overhead restrictions.

Your truck can be programmed to stop lowering to the floor.

To continue raising or lowering past the height limit, use the override function.

1. Return the raise or lower control to neutral.
2. Press and hold the override button and then slowly resume raise or lower.



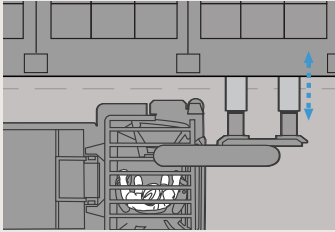

Telescopic Forks

The Telescopic Forks automatically extend and retract as you traverse. See **Traverse** on page 76.

To manually extend and retract the forks, press the override button and move the thumb ball.



Tilt

Right Multi-task Control Handle

- 1 Tilt Up 
- 2 Tilt Down 

Move the thumb ball to tilt the forks.

Note: The farther you move the thumb ball from neutral, the faster the forks will move.

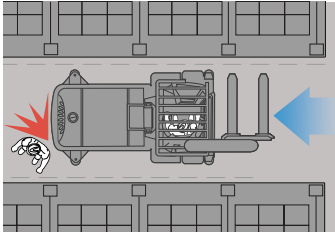

Warning

Stay alert

You must be just as careful using guided travel as you are traveling manually.

- Start slowly and look where you're going.
- Always be prepared to steer manually.
- Make sure your path is clear and nothing is sticking out of a rack.



Wire Guidance

With the Wire Guidance feature, your truck is guided by a wire in the floor. Make sure your path is clear and watch where you are going. Drive slowly and be alert for alarms or changes on the display showing wire guidance status.

Acquiring the Wire

Your direction of travel (power unit first or forks first) controls how you should approach the guidance wire.

1. Push the Wire Guidance switch to ON when you are close to a guided aisle.
2. Drive slowly and center the truck over the wire.

When you hear a "beep" and the widget stays green, the truck takes control of steering.



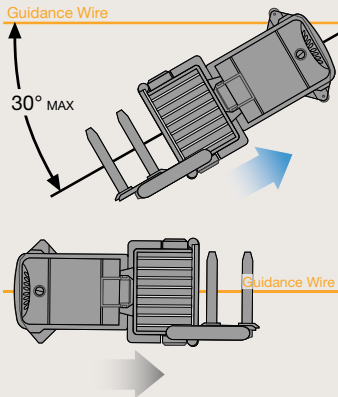

Traveling Guided Power Unit First

Drive slowly over the wire at an angle of 30° or less. When you hear a “beep” and the widget stays green, the truck takes control of steering. Start slowly.

Traveling Guided Forks First

If you must acquire the wire while traveling forks first, make sure you align your truck straight over the wire.

1. Drive slowly along the wire until you hear a “beep” and the widget stays green.
2. Continue to drive slowly for two truck lengths before increasing travel speed.

Automatic Slow Down

While traveling using wire guidance, your truck may slow down automatically for the following conditions:

- A low signal strength from the wire.
- The truck moves slightly from the wire.
- The End of Aisle Control option is active.

Automatic Stop

While traveling using wire guidance, your truck may stop automatically for the following conditions:

- The signal strength from the wire is lost or is too low.
- You acquire the wire at an angle greater than 30°.
- The truck moves too far from the wire.
- The End of Aisle Control option is active.

Continued on next page...



End of Aisle Control

With this feature, your company can program your truck to slow down or stop automatically when it comes to the end of an aisle. You will hear a “beep” and **End of Aisle** appears on the screen.

If your truck stops,

1. Return the travel control to neutral.
2. Press the override switch and resume travel.



Manual Steering

To return to manual steering, take control of the steering handle and turn off wire guidance.



Manual Wire Sense

Manual Wire Sense reminds you to turn ON the wire guidance.

With this feature, your truck will “beep” while traveling using manual steering on an active guidance wire. **Turn on Wire Guidance** appears on the screen.

Your company can program your truck to travel at a slow speed or slow to a stop while “beeping.”

Continued on next page...



Capacity Data Monitor

The Capacity Data Monitor can only assist you when handling loads. Depending on your truck settings, the Capacity Data Monitor widget shows you the following information:

- Load weight
- Lift height
- Lift height limit

Note: The information the Capacity Data Monitor shows is for reference only. Make sure that you understand the capacity of your truck. See **Capacity Plate** on page 32.

To use the Capacity Data Monitor, the fork carriage must be level.

The color of the widget changes depending on the weight and lift height of the load you are handling.

- Gray - appears when the load you are handling is within the lift height limit.
- Yellow - appears when the load you are handling is near the lift height limit.
- Red - appears if the load you are handling exceeds capacity or is above the lift height limit.

Follow the messages on the screen.

 **Caution****Know the load you are handling**

Do not rely only on the capacity data monitor. Check the load center, weight, and height of the load you are handling.

Continued on next page...

Warning

Do not rely on automatic feature to control your truck.

A moving truck can cause serious injury or death. Always come to a complete stop and check for pedestrians before entering an intersection.

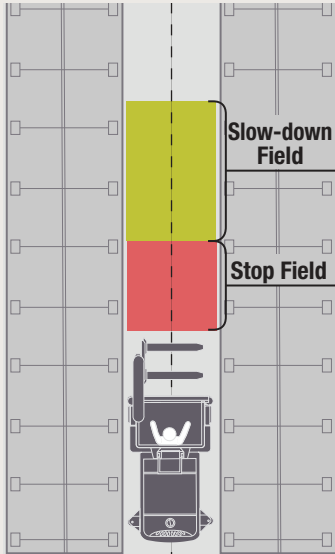

Pedestrian Detection System

The Pedestrian Detection System is a feature designed to slow and stop the truck in an aisle if objects are detected.

Slow-down Field

While traveling, the truck will slow down if an object is detected in the Slow-down Field as shown.

Stop Field

While traveling, the truck will stop if an object is detected in the Stop Field as shown.

When the Pedestrian Detection System has slowed or stopped the truck, check for any objects and make sure there is no one in the area.

If the truck has stopped, return the travel control to neutral and then press the override button to continue traveling.



Pedestrian Detection Screens

Information about the pedestrian detection system is shown as on-screen messages.

Watch out for pedestrians and obstructions anytime you're operating your truck.

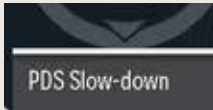

Travel speed is limited.



Pedestrian detection is disabled.



Object detected. Travel speed is reduced.

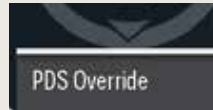

Press override to continue traveling.

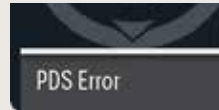

Travel speed is reduced. See your supervisor.

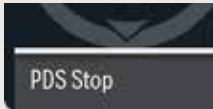

Remove any object and make sure the area is clear.



Pedestrian detection is disabled. Travel speed is reduced.

Continued on next page...

Warning

Do not rely on automatic feature to control your truck.

A moving truck can cause serious injury or death. Always come to a complete stop and check for pedestrians before entering an intersection.

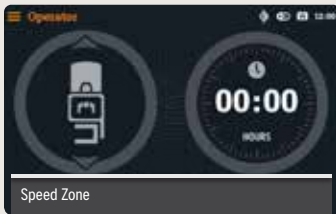

Auto Fence System

The Auto Fence System is a feature that allows your company to create virtual fences around specific zones to limit travel, raise, and lower.

You must be constantly aware of everything around the truck that could affect personal or pedestrian safety, such as the pallet, load, and rack conditions.

Travel Zones

Traveling into a speed or height zone can slow or stop your truck. Once in a zone, speed can be limited and travel can be restricted to one direction or not allowed.



While traveling or coasting in a designated travel zone, the following on-screen messages can appear:

- **SPEED ZONE** is shown on-screen when traveling or coasting in a zone that has a speed limit.
- **HEIGHT ZONE** is shown on-screen when traveling or coasting in a zone that has a height obstruction.
- **STOP ZONE** is shown on-screen when trying to travel in a speed zone or height zone where travel is restricted to one direction or not allowed.

If you cannot travel, return the travel control to neutral.

- Carefully lower or raise to exit the zone.
- Notify your supervisor.

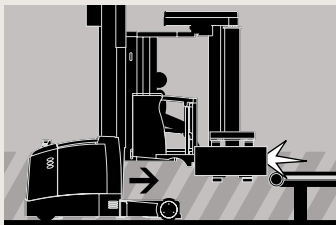

Raising and Lowering

When in a height zone, raising or lowering may not be allowed or will require the use of the Override Button to continue.

- **HEIGHT CUTOUT STOP** is shown on-screen when trying to raise in a height zone where raising is not allowed.
- **CUTOUT, USE OVERRIDE** is shown on-screen when trying to raise or lower in a height zone without pressing the Override Button. Return the Raise/Lower control to neutral. Press and hold the Override Button and then slowly resume raise or lower.



Continued on next page...

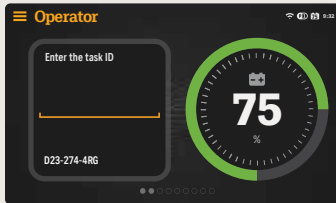

Auto Positioning System

The Auto Positioning System is a feature that improves productivity by helping you get to a task location as quickly as possible. The Auto Positioning System can only be used when the truck is guided, and after a task has been received and accepted by the operator. While traveling to a task location (as shown on the screen), the system will control raise/lower and stop the truck at the task location.



Using Auto Positioning System

To accept a task, click the AutoPivot button on the left control handle. The screen will then show the task location. To cancel the task, click the AutoPivot button again.

Removing your left hand from the control handle will interrupt auto raise/lower. To continue operation your hands must be on the control handles. Canceling a task will stop the Auto Positioning System.



You always have complete control of your truck. Moving the primary raise/lower handle or changing travel direction (plugging), will override the Auto Positioning System.

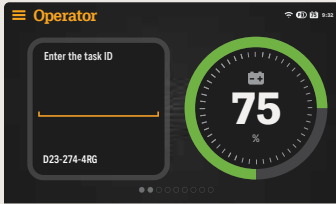

Auto Positioning System Widget

Information about the auto positioning system is shown on-screen.

Watch out for pedestrians and obstructions anytime you're operating your truck.



Continued on next page...



Cold Storage Option

Your truck can be operated in cold storage areas only if it is marked with the freezer symbol.

Caution

Batteries can freeze and rupture

- Do not park trucks in temperatures below freezing.
- Watch the charge status of the battery.
- Charge or replace the battery before the energy is too low.

Watch out for excess water on the truck

Make sure that your truck is completely dry before reentering cold storage areas.



Warning

Poor visibility can cause accidents

Do not operate the truck if the windows are not clear.

Use Your Truck Safely

The cab structure reduces visibility and your ability to hear sounds outside the cab. Be even more careful when operating around pedestrians or other vehicles.

Entering and Exiting the Cab

Your truck is equipped with a heated and ventilated cold store cab.

To enter the cab, press the release button and pull the handle to open the door. Climb aboard your truck and pull the handle to close the door.

To exit the cab, pull the release lever and push the door open.

Close the door after leaving the cab.

Note: To keep the cab warm, limit entering and exiting the cab in cold areas.

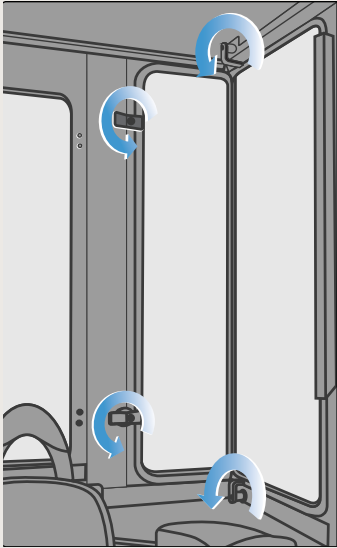

Exiting the Cab in an Emergency

If you cannot open the cab door, make sure it is safe to use emergency exit.

1. Lower the cabin and turn off the truck.
2. Push the emergency disconnect button.
3. Loosen and turn the four clamps to remove the corner windows.

Call for assistance.

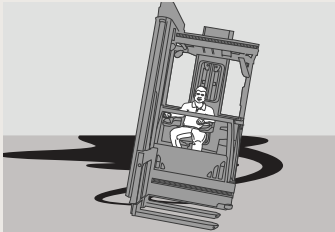
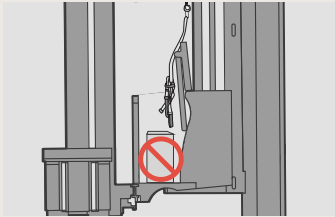
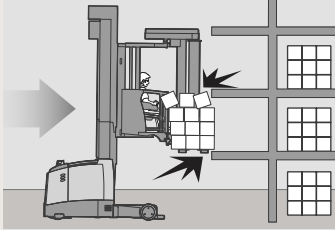

Be Cautious and Alert

- Look where you are going.
- You can be trapped or crushed by a fixed object.
- You can fall from the truck or the load can shift and hit you.
- Objects on the platform could trip you and affect truck operation. Always keep the operator compartment clear.
- Travel in the direction that gives you the best visibility. Slow down in congested areas.
- Never use cell phones or similar devices while operating your truck.
- Slow down for wet or slippery floors.
- Do not run over objects.
- Avoid sudden movement of controls. Learn to use them smoothly at a moderate, even rate.
- Travel at a speed that allows you to stop safely.
- Staying alert will help you be a better and safer operator.

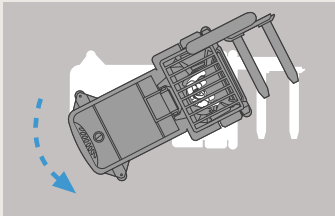
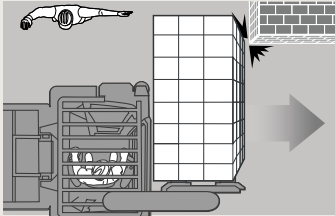
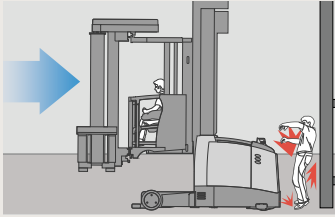

Watch Out for Other People

- Slow down. Yield or stop for pedestrians. Use the horn in areas such as intersections or crosswalks.
- Make sure that you do not trap or crush someone. *For example, never drive your truck toward anyone standing in front of a fixed object.*
- Be careful moving a wide or tall load. Make sure you or someone around you does not get trapped or crushed. Have a second person assist you.
- Keep others away from your truck while you are working.
- Watch out for power unit swing. Slow down when making turns.
- Travel in the direction that gives you the best visibility.
- Adjust the mirror to a position that allows you to see along the side of the truck and into the aisle behind you. Use the mirror only while maneuvering.
- Never allow passengers on your truck. Do not allow anyone to ride on the load or forks.

Continued on next page...



Avoid Falls and Tipovers

- Falling from a raised platform can cause a serious injury or death. Put the gates down and keep your entire body inside the operator compartment. Wear your harness and lanyard whenever you are working with an open side gate or a narrow front rail.
- The best way to prevent injury is to know where you are at all times. There is no sure way to avoid injury during a tipover or a drop from a dock.
- When traveling out of the aisle, keep the platform and forks close to the ground.
- Stay away from the edge of docks and ramps.
- An unloaded truck can tip over as well. Be just as careful using an unloaded truck as you are using one that is loaded.
- Make sure your truck, with a load, is not too heavy for where you are driving. *For example, elevators can have a different capacity than the floor.* Do not exceed any capacity.
- Make sure the load that you are moving is stable. Center the load. Be careful handling long, tall, or wide loads.

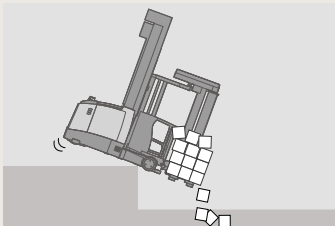

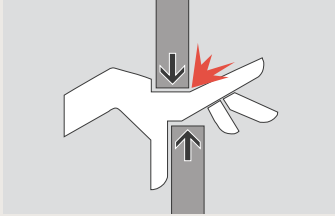

When Driving

- A foot or hand caught between the truck and a fixed object will be crushed or even cut off.
- Never stick a foot or any part of your body outside the operator compartment, no matter how slow the truck is moving.
- Before traveling, you must pivot the forks and traverse the load handler so they do not extend past the sides of the truck.
- When traveling, make sure that the load is centered.
- Make sure that there is clearance for your entire truck. Watch out for overhead obstructions
- Stop the truck completely before getting off.

Continued on next page...

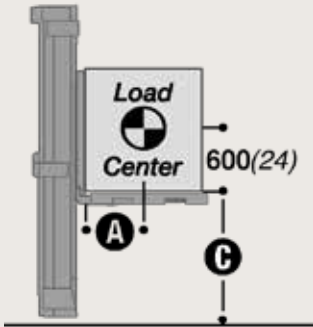
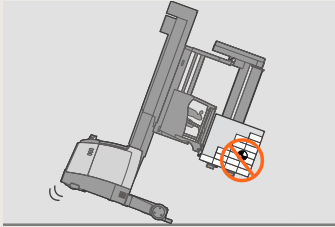

When Handling Loads

- Do not exceed the capacity shown on your truck's capacity plate.
- Travel with the load resting against the vertical face of the forks or load backrest. Make sure that the load is centered. The load center can differ from the visible center position on the forks.
- Make sure that the load you are moving is stable.
- Make sure that you spread the forks as far as possible.
- Be careful when using traverse, pivot, or other operations.
- Use minimum fork tilt to pick up or place a load. When raising or lowering outside a rack, keep the load backrest vertical or tilted back slightly.
- Be careful moving a wide or tall load.
- Stay away from all moving parts. *For example, do not reach into the mast area.*

When Leaving Your Truck

- Come to a complete stop and lower the forks before leaving your truck.
- Park on level floors.
- Log out, turn off your truck, and remove the key.

Check Your Truck Before Starting Work

You must make sure that your truck is safe to use.

See your supervisor for requirements in your workplace and local laws for inspection.

Note: If anything does not look, work, feel, or sound right, do not operate your truck. Notify to your supervisor.

1. Walk around your truck and check it over.

- Inspect your harness, lanyard, snap hooks and mounting points for damage. Have them replaced if they are worn or have ever been used to stop a fall.
- Check the battery connector, battery terminals, and battery cables for damage.
For flooded lead acid batteries:
 - Check the battery compartment for spilled acid.
 - After checking the water level, make sure that the vent caps are in place.
- Make sure that the battery is secure and the battery retainers are in place.
- Inspect the lift chains and anchors for damage and corrosion. Make sure that the lift chains are well lubricated.
- Check that all wheels are in good condition.
- Make sure that attachments are not damaged.

- Look under your truck for signs of hydraulic leaks.
- Make sure that the forks and fork carriage are not damaged or badly worn.
- Check that the mast guards are in place without damage or cracks. Keep the mast guards clear using a clean cloth.
- Check the overhead guard for damage and cracks.
- Test the horn.
- Check the capacity plate on your truck. Make sure you use the correct units of measure.
Note: If an attachment on your truck does not match the information on your capacity plate, don't operate your truck. Notify your supervisor.
- Turn on your truck and check that the display is working.
 - Check that the power source is charged.
 - Make sure that the emergency disconnect works.
 - Check that all controls move smoothly. All controls should automatically revert to their neutral position.

Continued on next page...

2. Test drive your truck in an uncongested area.

- Make sure that the pedals work.
- In an open area, drive the truck slowly in both directions. Check braking and plugging in forward and reverse. First check at a slow travel speed, then at a faster one.
- If at any time the stopping distance is too long for you, do not drive your truck.
- Test all hydraulic functions.
- Check the indicator or steering widget on the screen. Make sure that steering is easy and smooth. Know your steer angle.
- Check wire guidance operation.

Power Sources

Your truck can be designed to use the following power sources:

- Flooded Lead Acid Batteries
- Lithium-Ion Batteries

Only Crown approved power sources are permitted to be used in your truck. Only authorized service personnel are permitted to modify the power source installed in your truck.

Note: Follow the manufacturer's specification and instructions when handling power sources.

Working with Power Sources

Your company should provide an area that is safe to work on power sources. Use that area for all power source work and charging.

- Do not charge or refuel a power source unless you are trained and authorized.
- Do not remove or install a power source unless you are trained and authorized.
- Only use equipment approved for your truck and power source.

Continued on next page...



Power Source Status

The widget shows how much energy is available in the power source. The energy level is shown in the center of the widget and in the icon on the status bar.



When the energy level is low, the widget turns yellow showing an exclamation point in the center. The icon on the status bar turns yellow and flashes. Change or recharge the power source.



For power sources equipped with a second display, the widget on the truck screen shows "- -". Use the display installed on the power source to see the energy status.

 **Caution****Avoid damaging the power source**

Power sources that are not properly maintained will fail prematurely.

Always follow the manufacturer's instructions for the power source.

Before Charging Power Sources

- Read the instructions for the charger and power source.
- Make sure that the charger has the correct voltage and amperage for the power source.
- When charging power sources, use only chargers approved for the power source
- Only charge a power source in an authorized area.

Charging a Flooded Lead Acid Battery

1. Turn off your truck.
2. Unplug the power source connector from the truck.
3. Follow the charging instructions from the power source manufacturer.

When charging is complete, unplug the charger and plug the power source connector into the truck.

Charging a V-Force™ Lithium-ion Battery

1. Turn off your truck.
2. Plug the charger into the battery charge port.
3. Follow the charging instructions for the V-Force lithium-ion battery.

Opportunity charge during breaks or whenever the truck is not being used.

When opportunity charging is complete or the battery is fully charged, unplug the charger from the battery charge port.

 **Caution**

Avoid damaging the truck and power source charger

Make sure that the power source charger is plugged into the power source connector, not the truck connector.



Danger

Lead acid batteries produce gas that can explode

You can cause sparks which can damage the battery.

- Never let anything conductive like metal touch the top of the cells. Use an insulator such as plywood, when necessary.
- Never smoke or use an open flame around batteries.
- Make sure that the battery cells are filled to the proper level.
- Ventilate well when in an enclosed area and when charging.

Avoid contact with battery acid

Battery acid can cause severe burns.

- Use protective equipment such as gloves, eye shields, aprons, etc.
- In case of contact, remove clothing. Flush skin and eyes immediately and thoroughly with water.
- Get medical attention if your eyes are affected.

Removing the Battery

Before removing a battery, perform the following steps:

1. Park on a level floor.
2. Lower the forks completely.



Disconnecting the Battery

- 1 Battery Cable
- 2 Battery Connector

To disconnect the battery, perform the following steps:

1. Turn off your truck and remove the key if equipped.
2. Disconnect the battery connector.
3. Place the battery connector and battery cable on top of the battery.

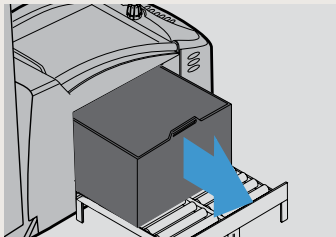
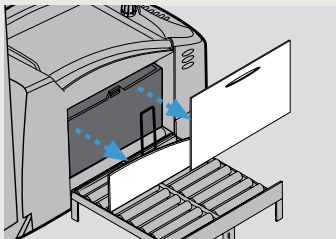

Rolling out the Battery

Make sure that the roller stand is the correct size for your truck and battery.

1. Place the roller stand next to the truck.
2. Lift up and pull out the side cover and battery retainer.
3. Move the battery onto the roller stand.

Continued on next page...

Warning

Check the size and type of the battery

An incorrect battery can affect truck handling and stability causing an accident.

Make sure that you use the correct size, type, and weight of battery.

Check the battery retainer

Unsecured batteries can slide or roll out of the truck.

Make sure that all battery retainers are installed before operating your truck.

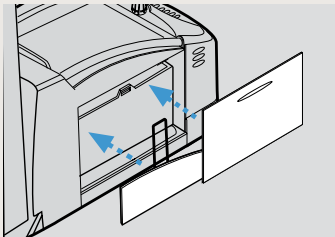

Installing the Battery

Make sure that the new battery is ready for use. Place the battery connector and battery cable on top of the battery.

1. Install the new battery.
2. Replace the battery retainer and side cover.
3. Connect the battery to the truck.
4. Turn on your truck and check truck operation.
Follow the on-screen messages.

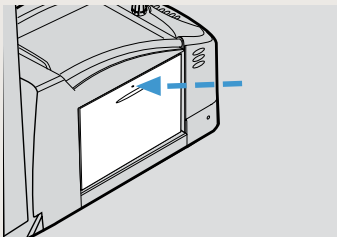

Note: Make sure you know your Truck Type. See **Capacity Plate** on page 34. For EE Truck Types, make sure to lock the side cover.

Each Warning Label On Your Truck Is Important Read and obey all of them to protect yourself and others.

WARNING

Minimum battery size allowed
XX mm (XX.XX in.) wide
XXX mm (XX.XX in.) long
Undersize battery can affect
truck handling and stability. You
could have an accident.
Use U.L. classified Type EO battery.

WARNING

A moving truck can cause serious injury.
Always come to a complete stop and check for
pedestrians before entering an intersection.
Do not rely on automatic features to control
your truck.

WARNING

Poor visibility can cause
accidents.
Do not operate truck if
windows are not clear.

WARNING

Passengers could be
seriously injured. There is
no safe place for them.
No Passengers.

WARNING

There are blind spots not
covered by the mirror.
You could hit someone not
visible in the mirror.
**Don't drive with the mirror,
look in direction of travel,
of travel.**

EMERGENCY EXIT

Lower the cabin if necessary.
Shut the truck off and push
the emergency disconnect
button.
Loosen and turn the four
clamps to remove the corner
windows.
Call for assistance.
Exit cabin through opening.
Use caution.

WARNING

**Stay clear of all
moving parts.**

Moving parts can cut
or crush hands, feet,
arms or legs.

! DANGER

Batteries can produce explosive gas. Do
not smoke, use open flame, or create an arc or
sparks near this battery. Ventilate well when in
an enclosed area and when charging.
This battery contains **Sulfuric Acid** which
causes severe burns. Do not get in eyes, on
skin, or clothing. In case of contact, flush
immediately and thoroughly with water. Get
medical attention if your eyes are affected.

WARNING

Falling objects or lowering forks can
cause serious injury or death.
Never stand under the forks.
While servicing, block the forks so
they won't fall.

WARNING

Standing or riding on the forks can
cause a fall. You can be seriously
injured or killed.
**Never stand or ride on
forks for any reason.**

WARNING

**Keep all body parts within
the operator compartment
while performing any
emergency operations.
Emergency Traverse
Switch**

- To traverse out of the
rack, press this switch
while your assistant on the
floor presses the power unit
traverse switch.
- To Traverse into the rack,
press the switch a second
time.

! CAUTION

WARNING

**Warn operator to keep all body
members within the operator
compartment while performing
any emergency operation.**

Emergency Lowering Valve

Before using valve:

- Check that the area under forks
is clear.
- Make certain the forks are clear
of the rack. (See Below) Close
valve immediately if chains
become slack.

WARNING

STOP

It's the law, you must be trained
and certified to operate this truck.
(OSHA § 1910.178, Rev. 1999)

You or people around you could be seri-
ously injured or even killed if you don't use
this truck correctly.

Obey all warnings and instructions on the
truck and in the operator manual.
Inspect your truck before starting work,
make sure it is in good working order.

WARNING

Truck does not automatically
slow down at end of aisles.
Cross traffic does not stop.
Slow Down, look out for
people and other trucks.

WARNING

Emergency Traverse Switch

Press and hold this switch while
the operator actuates the
emergency traverse switch on the
platform.
With the platform switch, the
operator can traverse out of or
into the rack.

WARNING

Operate this truck only with an approved
electric power source.
This truck as designed and manufactured
from the factory is qualified for use with a
lead acid battery and if configured,
Crown V-Force products.
Written approval must be obtained from Crown
prior to installation of a new type of electric
power source. OSHA 1910.178 (a)

WARNING

Unsafe loads can swing or fall
into the operator area causing
serious injury.
**Never operate the truck with
a load that is off-center,
oversize, or unstable.**

WARNING

**Avoid being
crushed.** Keep head,
arms, hands, legs,
and feet within the
operator area. **Stop
truck completely
before getting off.**

Tipovers and falls can
cause serious injury
or even death. Do not
overload truck. **Use
extreme caution
near docks or on
dockplates.**

! DANGER

Falling from a raised platform can cause serious
injury or even death.
**Attach safety harness and lanyard when elevated
and working with an open side gate or with
narrow front gate option.**

Trademarks

The following trademarks are property of Crown Equipment Corp. in the United States and other countries.

Your truck is equipped with the following standard features and may be equipped with optional features.

The logo for ecologic, featuring the word "ecologic" in a lowercase, sans-serif font. The "eco" portion is green, and "logic" is black. A small trademark symbol (TM) is located at the top right of the word.The logo for Crown Insite. It features the word "CROWN" in a small, uppercase, sans-serif font above the word "Insite". "Insite" is in a large, bold, lowercase, sans-serif font. A stylized Wi-Fi symbol is positioned above the "i" in "Insite". A small trademark symbol (TM) is at the top right.The logo for Digena. It features a stylized orange fingerprint icon to the left of the word "Digena" in a lowercase, sans-serif font. A small trademark symbol (TM) is at the top right.

Options:

The logo for InfoLink. It features the word "InfoLink" in a bold, lowercase, sans-serif font. The "i" in "Info" is stylized with a circular arrow around it. A small trademark symbol (TM) is at the top right.The logo for V-Force. It features a stylized orange and black "V" shape followed by the word "FORCE" in a bold, italicized, uppercase, sans-serif font.

© 1996-2022

Printed in USA

600099-200 Rev. A



EN-NA

Operator Manual

