

**CROWN**

# C-G

2,000 - 3,500 kg Capacity

**LPG Counterbalance Lift Truck**





# Strength and Refinement

With a durable heavy-duty chassis, dependable LPG engine and refined ergonomic cabin, the Crown C-G Series LPG counterbalance forklift is ready to work hard all shift long. The C-G Series also complies with the latest EU 5 exhaust emission regulations.

Its wide range of standard and optional product features makes it an ideal choice for virtually any IC material handling environment.

**The C-G Series is built to go the distance.**



# Outstanding Comfort and Control

Crown's C-G Series LPG counterbalance forklifts are equipped with features that can take your productivity to the next level without compromising safety, comfort or control. Enhanced comfort features reduce operator fatigue and strain, even in demanding applications.

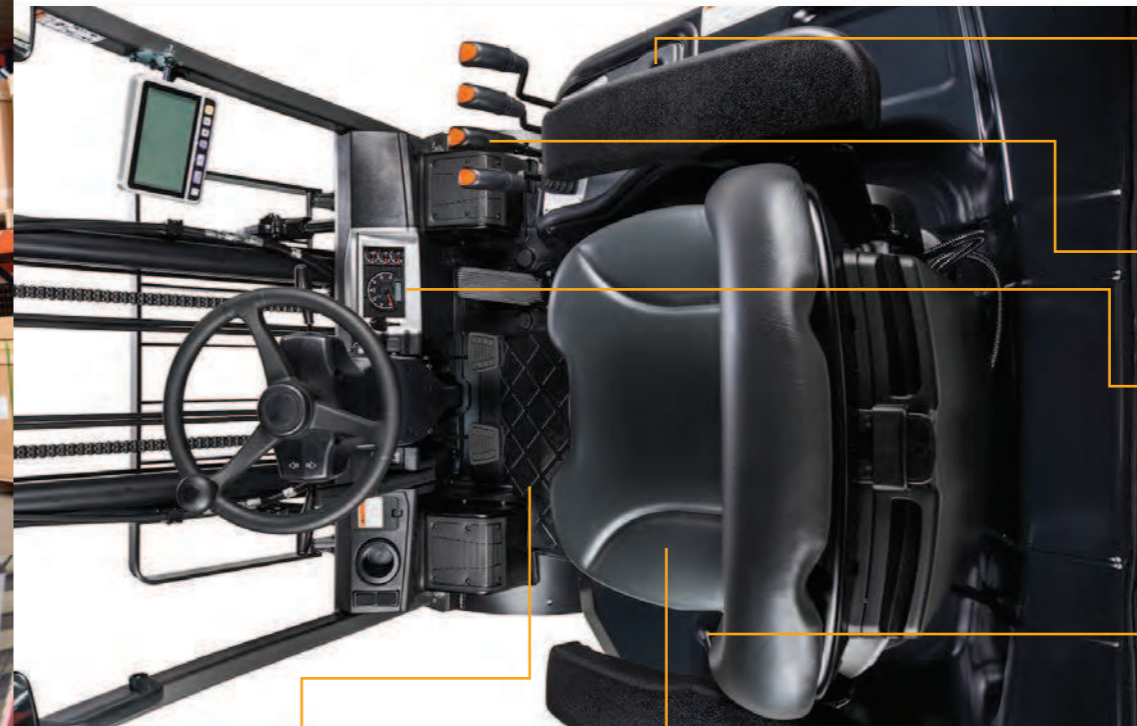

**Electronic Parking Brake**  
The parking brake is automatically activated when the operator stops working and gets off the forklift, helping to prevent accidents.

**Ergonomic Controls**  
Available with manual levers.

**Intuitive Instrument Panel**  
Easy-to-read 5-inch colour display shows operators important information. Changes to performance settings are simple and quick.

**Spacious Legroom**  
The wide knee clearance and the covered tilt cylinders provide plenty of legroom and enable easy entry and exit.



**Excellent Visibility**  
The overhead guard design adds strength for safety and allows for a clear upward view for operators. The low front dashboard improves sight lines for load handling operations.

- Hydraulic hoses and chains are arranged strategically, near to the mast uprights, to provide a wide-open view
- Optional large panoramic mirror assists the operator with a clear view of the rear working area
- Optional Tilt Position Assist

**Premium Adjustable Seat (optional)**  
A full-suspension Grammer comfort seat can accommodate individual operator preferences.

**High-Visibility Seat Belt**  
The seat belt must be fastened when the operator is seated in order to operate the forklift.

**Operator Sensing System**  
An operator must be seated for the forklift to function.

**Modular Cabins (optional)**  
Four individually adaptable cabin layouts are available for protection in different conditions

- Roof only
- Roof and front windshield
- Roof, front windshield and rear window
- Hard cabin, also available with heat and air conditioning



**Floor Spotlights (optional)**



# Crown's Proven Service and Support

Crown support begins long before the lift truck leaves the factory. Our integrated approach to service provides an exceptional user experience to our customers – before, during and after the sale.



## Virtually Maintenance-Free Oil-Cooled Disc Brakes

Fully enclosed, oil-cooled dual disc brake assemblies prevent contamination for exceptional stopping power and long life. The virtually maintenance-free discs are submerged in oil, keeping them cool and limiting wear.



## Dual Element Air Cleaner

A heavy-duty dual element air cleaner provides advanced protection against engine contamination. The elements are easily accessible through a clip-on cover.



## 2.4 Litre Industrial Engine

This engine includes a silent timing chain that aids in the reduction of noise levels and helps to improve efficiency. An aluminium cylinder block and oil pan also help to reduce noise. Additionally, fuel efficiency is increased thanks to the use of abrasion-resistant materials and specially designed 'beehive type' valve springs.

## Enhanced Cooling System

The combination of a large capacity radiator and the special counterweight design optimises airflow to improve cooling capabilities and increases uptime in heavy-duty applications.

## Easy to Access Components

Toolless panel removal and generous hood opening allow for quick checks and easy access to serviceable components.



## Easy Diagnostics

The forklift's condition can be diagnosed with just a cable and a laptop, allowing the service technician to maintain your forklift as quickly as possible.



## Crown Gabelstapler GmbH & Co. KG

Philipp-Hauck-Str. 12  
85622 Feldkirchen, Germany

**Tel** +49(0)89-93002-0

**Fax** +49(0)89-93002-133

**crown.com**

Because Crown is continually improving its products, specifications are subject to change without notice.

Notice: Not all products and product features are available in all countries in which this literature is published.

Crown, the Crown logo, the colour beige and the Momentum symbol are trademarks of Crown Equipment Corporation in the United States and other countries.

Copyright 2022 Crown Equipment Corporation  
C-G 20-35 BROCH GB 09/22, 10 - M01535-006-00  
Printed in Germany

**CROWN**

# C-G

3,500 - 5,500 kg Capacity

**LPG Counterbalance Lift Truck**





# Robust and Reliable

With load capacities from 3,500 to 5,500 kg, Crown's C-G Series LPG-powered counterbalance forklifts deliver powerful and fuel-efficient performance whilst providing excellent value. The C-G Series also complies with the latest EU 5 exhaust emission regulations.

Its outstanding visibility, durable design and comprehensive range of standard and optional features are designed for safe operation in virtually any IC material handling environment.



# Outstanding Comfort and Control

Crown's C-G Series LPG-powered counterbalance forklifts are designed for comfort, confidence, stability and safety, so operator productivity can keep pace with lift truck performance. Enhanced comfort features reduce operator fatigue and strain, even in the most demanding applications.

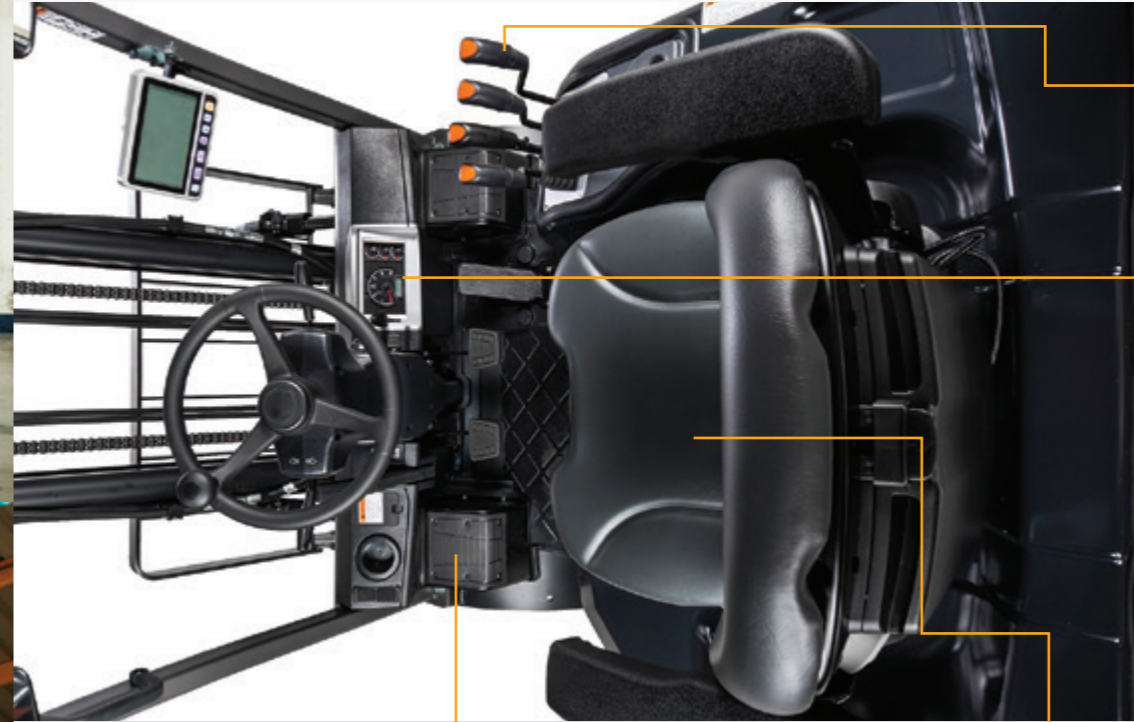

**Ergonomic Controls**  
Available with manual levers.

**Intuitive Instrument Panel**  
Easy-to-read 5-inch colour display shows operators important information. Changes to performance settings are simple and quick.

**Mast Lowering Interlock (optional)**  
The hydraulic locking system prevents lowering and tilting of the mast when the forklift is not in operation (ISO 3691 compliant).

**Operator Sensing System**  
An operator must be seated for the forklift to function.

**Tilt Cylinder Covers**

The covers protect the tilt cylinders against unexpected shocks and provide extra space for the operator.

**Anti-Slip Step Plate**

The large anti-slip step plate makes it easy to get on and off the forklift, even in extreme weather conditions.



**Modular Cabins (optional)**

Four individually adaptable cabin layouts are available for protection in different conditions

- Roof only
- Roof and front windshield
- Roof, front windshield and rear window
- Hard cabin, also available with heat and air conditioning

**Premium Adjustable Seat (optional)**  
A full-suspension Grammer comfort seat can accommodate individual operator preferences.



**Accurate Pedal Power**  
The inching pedal design increases operator control while comfort is ensured through the use of an anti-slip pedal covering.



# Crown's Proven Service and Support

Crown support begins long before the lift truck leaves the factory. Our integrated approach to service provides an exceptional user experience to our customers – before, during and after the sale.



### Easy Mounting/Dismounting of LPG Tank

The specially designed LPG cradle smoothly swings the tank out and down from its position on the counterweight, providing operators with an easier method for mounting and dismounting LPG tanks.

### Easy to Access Components

Toolless panel removal and generous hood opening allow for quick checks and easy access to serviceable components.

### Virtually Maintenance-Free Oil-Cooled Disc Brakes

Fully enclosed, oil-cooled dual disc brake assemblies prevent contamination for exceptional stopping power and long life. The virtually maintenance-free discs are submerged in oil, keeping them cool and limiting wear.



### Dual-Element Air Cleaner

A heavy-duty dual-element air cleaner provides advanced protection against engine contamination. The elements are easily accessible through a clip-on cover.



### 3.8 Litre Engine

Well-proven and reliable engine and components provide high-end torque at low engine rpm and reduced fuel consumption. It delivers great performance and reliability.



### Crown Gabelstapler GmbH & Co. KG

Philipp-Hauck-Str. 12  
85622 Feldkirchen, Germany

**Tel** +49(0)89-93002-0

**Fax** +49(0)89-93002-133

**crown.com**

Because Crown is continually improving its products, specifications are subject to change without notice.

Notice: Not all products and product features are available in all countries in which this literature is published.

Crown, the Crown logo, the colour beige and the Momentum symbol are trademarks of Crown Equipment Corporation in the United States and other countries.

Copyright 2022 Crown Equipment Corporation  
C-G 35-55 BROCH GB 01/24, 10 – M01555-006-01  
Printed in Germany