

CROWN

SC 6000 SERIES

Specifications

Three and Four Wheel
Counterbalance Truck



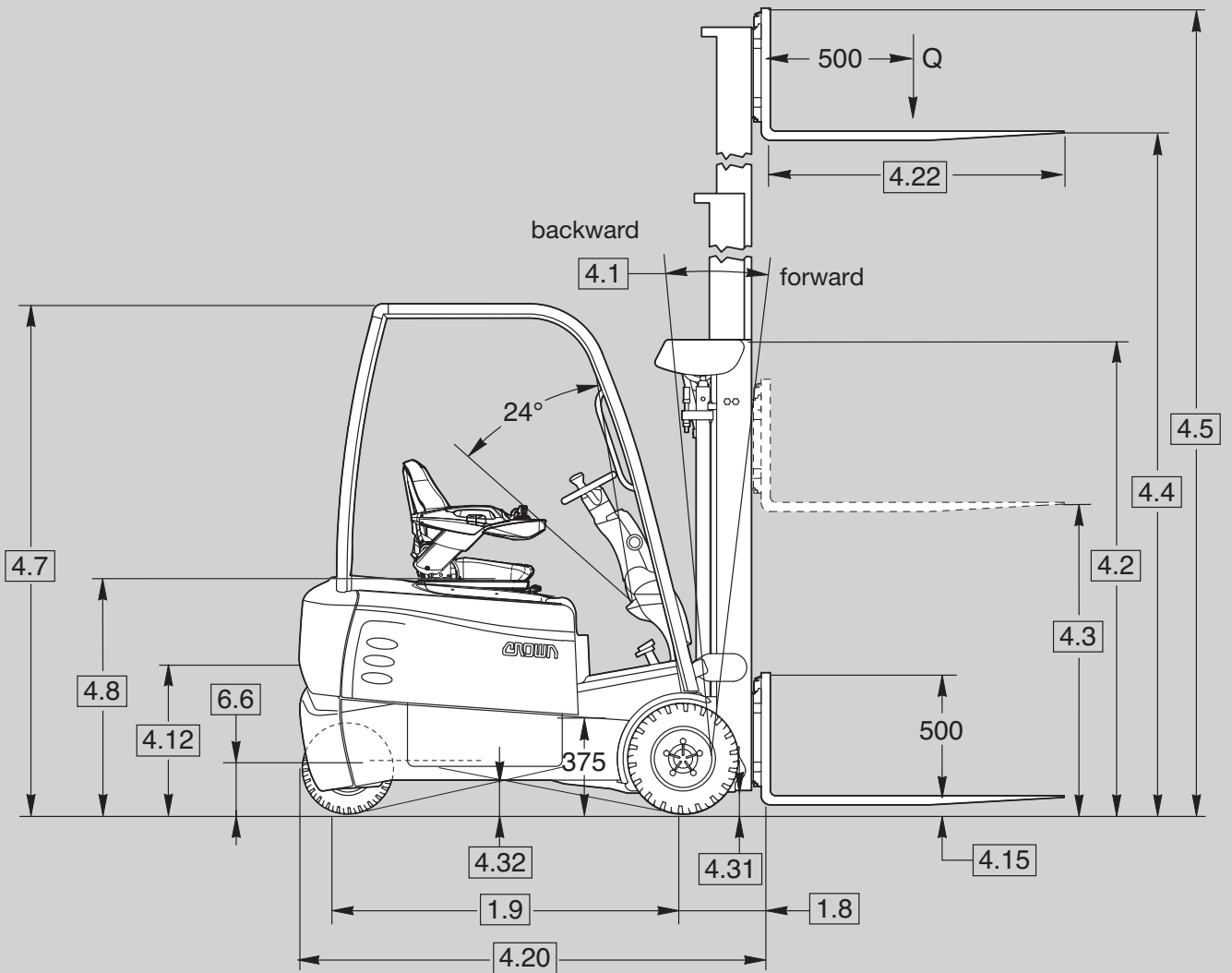
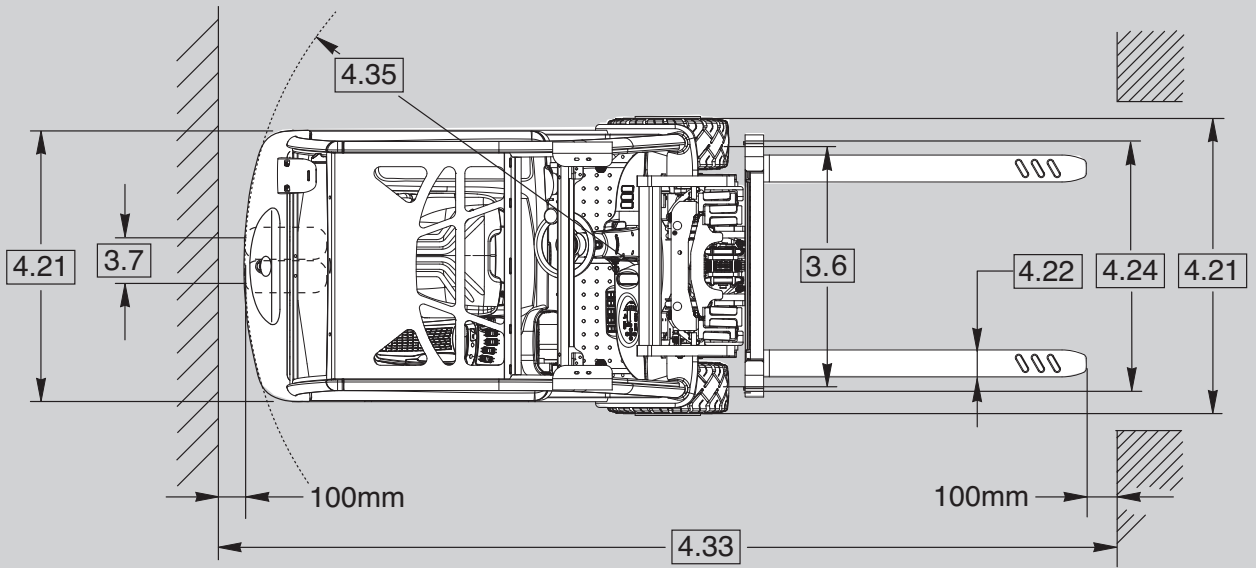

SC 6000 Series

Specifications

General Information	1.1	Manufacturer	Crown Equipment Corporation									
	1.2	Model				SCT 6010	SCT 6020	SCT 6020	SCT 6040	SCT 6040	SCT 6060	SCT 6060
	1.3	Power	electric			1.3	1.3	1.6	1.6	1.8	1.8	2.0
	1.4	Operator Type				sit down						
	1.5	Load Capacity		Q	t	1.3	1.3	1.6	1.6	1.8	1.8	2.0
	1.6	Load Centre		c	mm	500						
	1.8	Load Distance		x	mm	316*				366*		
	1.9	Wheel Base		y	mm	1174	1282		1390		1498	
	Weights	2.1	Weight	less battery		kg	2420	2528	2528	2602	2621	2699
2.2		Axle Load	w. load front/rear		kg	3518/734	3548/953	4039/762	4074/941	4549/685	4576/884	4891/769
2.3		Axle Load	w.o. load front/rear		kg	1314/1638	1421/1780	1421/1780	1535/1880	1628/1805	1735/1926	1735/1926
Tyres	3.1	Tyre Type				Super Elastic / SE						
	3.2	Tyres	front			18x7-8			200/50-10			
	3.3		rear			140 / 55 - 9						
	3.5	Wheels	no. (x=driven) front/rear			2x / 2						
	3.6	Track Width	load side	b10	mm	919			922			
	3.7		power unit side	b11	mm	176						
Dimensions	4.1	Mast Tilt	forward/backward		°	see table 1			see table 2			
	4.2	Mast	collapsed height	h1	mm	see table 1			see table 2			
	4.3	Free Lift	w. / w.o. lbr	h2	mm	see table 1			see table 2			
	4.4	Lift Height		h3	mm	see table 1			see table 2			
	4.5	Mast	extended height	h4	mm	see table 1			see table 2			
	4.7	Overhead Guard Height	standard/opt. low	h6	mm	2105 / 1990						
	4.8	Seat Height		h7	mm	1078						
	4.12	Tow Hitch Height		h10	mm	520						
	4.15	Lowered Fork Height		h13	mm	45						
	4.20	Headlength *		l2	mm	1696	1804	1804	1912	1963	2071	
	4.21	Overall Width		b1/b2	mm	1070			1129			
	4.22	Fork Dimension		thxw	mm	38x100			45x100			
			standard/option	l	mm	990 / 760, 915, 1065, 1145, 1220, 1370, 1525						
	4.23	Fork Carriage	ISO/FEM	b5	mm	2 A						
	4.24	Fork Carriage Width	w. lbr / w.o. lbr	b3	mm	990 / 965						
4.31	Ground Clearance	with load below mast	m1	mm	76							
4.32		centre wheel base	m2	mm	108							
4.33	Working Aisle Width	minimum		mm	see table 3							
4.35	Turning Radius		Wa	mm	1390	1493		1597		1704		
Performance	5.1	Travel Speed	w./w.o. load		km/h	16 / 16 **						
	5.2	Lift Speed	w./w.o. load		m/s	0.55/0.56			0.52/0.56		0.49/0.56	
	5.3	Lower Speed	w./w.o. load		m/s	0.50/0.50						
	5.5	Drawbar Pull	w./w.o. load (60 min. rtg.)	N		2336/2591	2284/2539	2225/2539	2180/2494	2137/2490	2090/2443	2050/2443
	5.6	Max. Drawbar Pull	with load	N		12635	12584	12525	12480	12437	12389	12350
			without load	N		12890	12839	12839	12794	12790	12742	12742
	5.7	Gradeability	w./w.o. load (60 min. rtg.)	%		11.5/17.4	10.8/15.8	10.0/15.8	9.4/14.6	9.0/14.5	8.5/13.5	8.1/13.5
	5.8	Max. Gradeability	w./w.o. load (intermit)	%		30.6/46.8	28.6/42.3	26.6/42.3	25.3/39.0	24.1/38.7	22.9/35.8	22.0/35.8
	5.9	Acceleration Time	w./w.o. load	s		4.4 / 3.8	4.5 / 3.9	4.5 / 3.9	4.6 / 4.0	4.6 / 4.0	4.7 / 4.1	4.7 / 4.1
	5.10	Brake	service			Regenerative electric motor brake						
park					Spring applied and electrically released							
Motors	6.1	Traction Motor	60 min. rating		kW	2 x 5.5						
	6.2	Lift Motor	15% on time		kW	11.2						
	6.3	Max. Battery Box Size	DIN 43531	l	mm	414	522		630		738	
			Layout A	wxh	mm	830 x 627						
	6.4	Battery Voltage	Voltage		V	48						
			min./max.		Ah	330-360	440-480		550-625		660-750	
6.5	Battery Weight	min./max.		kg	532/588	673/743		814/898		963/1063		
6.6	Battery Floor Height	with/without rollers		mm	210 / 204							
Misc.	8.1	Type of Control	drive/lift			Transistor						
	8.2	Available Working Pressure for Attachments			bar	235						

* add 36 mm for Crown integrated sideshift, add 59 mm for Cascade hook on sideshift or fork positioner, add 79.5 mm for Rightline hook on fork positioner

** travel speed reduction applicable to trucks with lift height above 2260 mm collapsed height

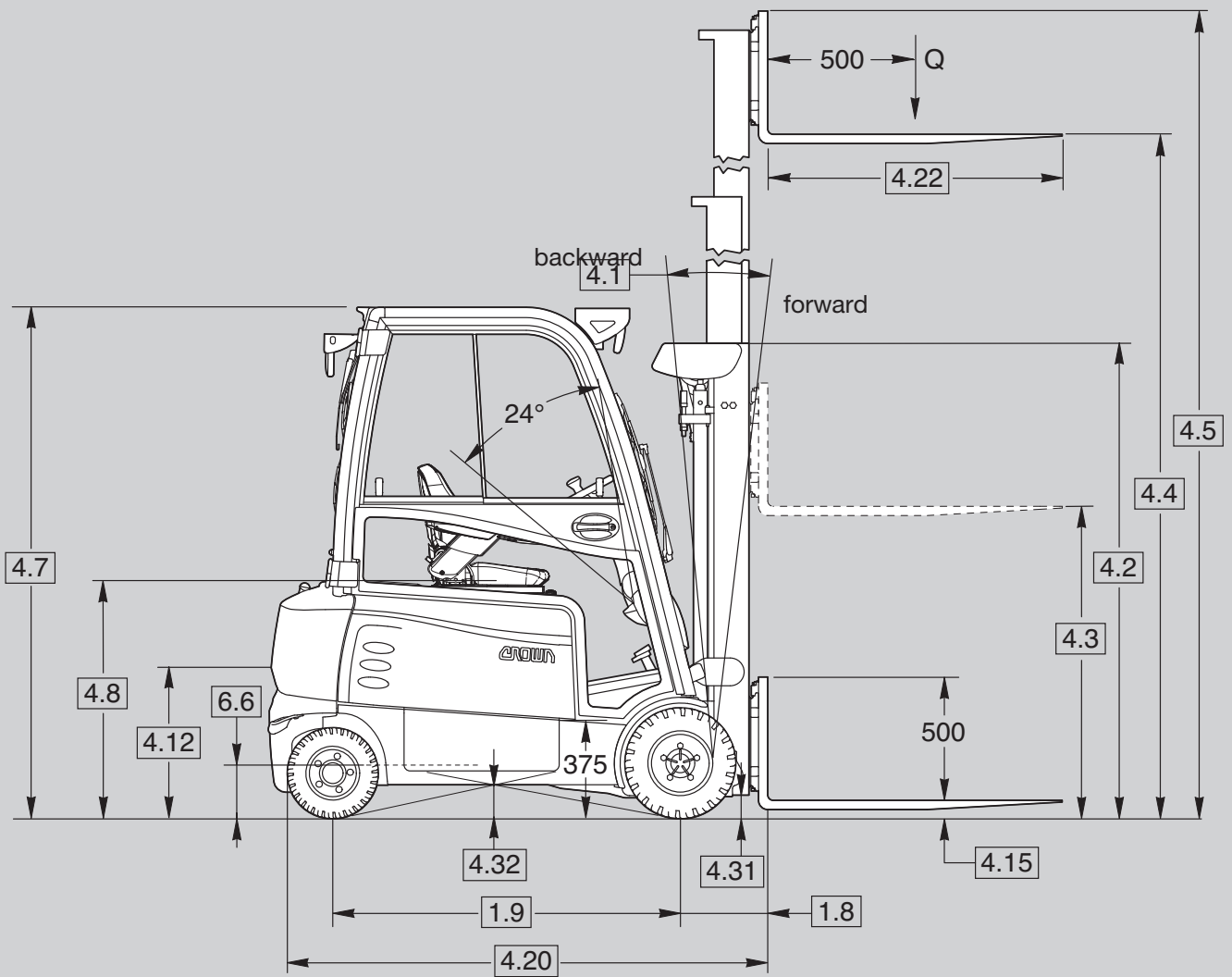
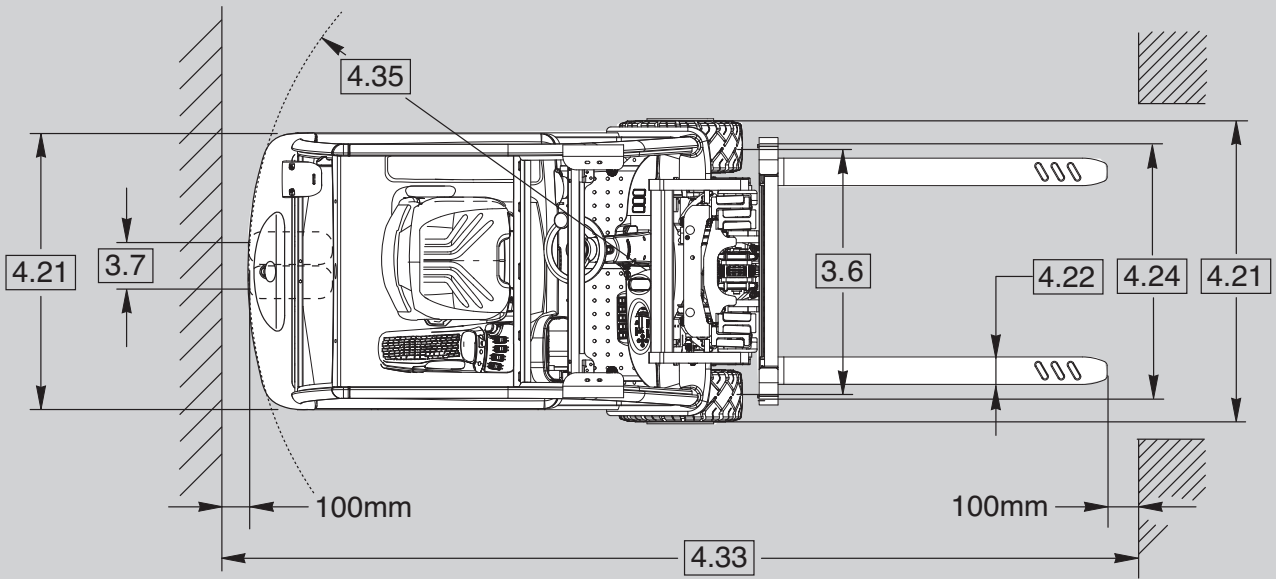

shown with cabin option

SC 6000 Series

Specifications

General Information	1.1	Manufacturer				Crown Equipment Corporation			
	1.2	Model				SCF 6040	SCF 6040	SCF 6060	SCF 6060
						1.6	1.8	1.8	2.0
	1.3	Power	electric			battery			
	1.4	Operator Type				sit down			
	1.5	Load Capacity		Q	t	1.6	1.8	1.8	2.0
	1.6	Load Centre		c	mm	500			
	1.8	Load Distance		x	mm	316*	366*		
	1.9	Wheel Base		y	mm	1439			1547
Weights	2.1	Weight	less battery		kg	2570	2743	2767	2767
	2.2	Axle Load	w. load front / rear		kg	3998/985	4546/810	4571/958	4883/846
	2.3	Axle Load	w.o. load front / rear		kg	1491/1892	1663/1893	1763/1966	1763/1966
Tyres	3.1	Tyre Type				Super Elastic / SE			
	3.2	Tyres	front			18x7-8	200/50-10		
	3.3		rear			140 / 55 - 9			
	3.5	Wheels	no. (x=driven) front/rear			2x / 2			
	3.6	Track Width	load side	b10	mm	919	922		
	3.7		power unit side	b11	mm	888			
	Dimensions	4.1	Mast Tilt	forward / backward		°	see table 1	see table 2	
4.2		Mast	collapsed height	h1	mm	see table 1	see table 2		
4.3		Free Lift	w. / w.o. lbr	h2	mm	see table 1	see table 2		
4.4		Lift Height		h3	mm	see table 1	see table 2		
4.5		Mast	extended height	h4	mm	see table 1	see table 2		
4.7		Overhead Guard Height	standard/optional low	h6	mm	2105 / 1990			
4.8		Seat Height		h7	mm	1078			
4.12		Tow Hitch Height		h10	mm	520			
4.15		Lowered Fork Height		h13	mm	45			
4.20		Headlength *		l2	mm	2011	2062	2170	
4.21		Overall Width		b1/b2	mm	1070	1129		
4.22		Fork Dimension		thxw	mm	38x100	45x100		
			standard / option	l	mm	990 / 760, 915, 1065, 1145, 1220, 1370, 1525			
4.23		Fork Carriage	ISO / FEM	b5	mm	2 A			
4.24		Fork Carriage Width	w. lbr / w.o. lbr	b3	mm	990 / 965			
4.31	Ground Clearance	with load below mast	m1	mm	76				
4.32		centre wheel base	m2	mm	108				
4.33	Working Aisle Width	minimum		mm	see table 3				
4.35	Turning Radius		Wa	mm	1709			1816	
Performance	5.1	Travel Speed	w./w.o. load		km/h	16 / 16 **			
	5.2	Lift Speed	w./w.o. load		m/s	0.55/0.56	0.52/0.56		0.49/0.56
	5.3	Lower Speed	w./w.o. load		m/s	0.50/0.50			
	5.5	Drawbar Pull	w./w.o. load (60 min. rtg.)		N	2186 / 2500	2113 / 2466	2109 / 2462	2037 / 2429
	5.6	Max. Drawbar Pull	with load		N	12486	12413	12408	12337
			without load		N	12800	12766	12761	12729
	5.7	Gradeability	w./w.o. load (60 min. rtg.)		%	9.5 / 14.8	8.7 / 14.0	8.7 / 13.9	8.0 / 13.2
	5.8	Max. Gradeability	w./w.o. load (intermit)		%	25.5 / 39.4	23.5 / 37.2	23.4 / 36.9	21.7 / 35.1
	5.9	Acceleration Time	w./w.o. load		s	4.5 / 3.9	4.6 / 4.0	4.7 / 4.1	4.7 / 4.1
	5.10	Brake	service			Regenerative electric motor brake			
park					Spring applied and electrically released				
Motors	6.1	Traction Motor	60 min. rating		kW	2 x 5.5			
	6.2	Lift Motor	15% on time		kW	11.2			
	6.3	Max. Battery Box Size	DIN 43531	l	mm	630			738
			Layout A	wxh	mm	830 x 627			
	6.4	Battery Voltage	Voltage		V	48			
			min./max.		Ah	550-625			660-750
6.5	Battery Weight	min./max.		kg	814/898			963/1063	
6.6	Battery Floor Height	with / without rollers		mm	210 / 204				
Misc.	8.1	Type of Control	drive / lift			Transistor			
	8.2	Available Working Pressure for Attachments			bar	235			

* add 36 mm for Crown integrated sideshift, add 59 mm for Cascade hook on sideshift or fork positioner, add 79.5 mm for Rightline hook on fork positioner

** travel speed reduction applicable to trucks with lift height above 2260 mm collapsed height

Table 1 – Mast Chart SC 6000 1.3/1.6

				TL Mast									
				SC 6010 SC 6020 SC 6040									SC 6020 SC 6040
4.1	Tilt	forward/backward	°	5/5*	5/5	5/5	5/3	5/3	5/3	5/3	5/3	5/3	5/3**
4.2	Collapsed Height		h1 mm	1955	2105	2260	2410	2540	2665	2840	3035	3225	3350
4.3	Free Lift		h2 mm	150	150	150	150	150	150	150	150	150	150
4.4	Lift Height		h3 mm	2895	3200	3505	3810	4060	4190	4545	4925	5305	5560
4.5	Extended Height	w.o. load backrest	h4 mm	3435	3740	4045	4350	4600	4730	5085	5465	5845	6100
	Extended Height	with load backrest	h4 mm	4115	4420	4725	5030	5280	5410	5765	6145	6525	6780

* 5/3 with front panel (Windshield)

** Not available in combination with cab options on the SCT only

				TF Mast					Quad	
				SC 6010 SC 6020 SC 6040					SC 6010 SC 6020 SC 6040	
4.1	Tilt	forward / backward	°	5/5	5/5	5/5	5/3	5/3	5/3	
4.2	Collapsed Height		h1 mm	1955	2105	2260	2410	2540	2105	
4.3	Free Lift	without load backrest	h2 mm	1445	1595	1750	1900	2030	1500	
		with load backrest	h2 mm	735	885	1040	1190	1320	885	
4.4	Lift Height		h3 mm	2970	3275	3580	3885	4140	6095	
4.5	Extended Height	w.o. load backrest	h4 mm	3480	3785	4090	4395	4650	6635	
	Extended Height	with load backrest	h4 mm	4190	4495	4800	5105	5360	7315	

				TT Mast								
				SC 6010 SC 6020 SC 6040								SC6020 SC6040
4.1	Tilt	forward / backward	°	5/5*	5/5	5/5	5/3	5/3	5/3	5/3	5/3**	5/3
4.2	Collapsed Height		h1 mm	1955	2105	2260	2410	2540	2665	2840	3035	3225
4.3	Free Lift	without load backrest	h2 mm	1445	1595	1750	1900	2030	2155	2330	2525	2715
		with load backrest	h2 mm	735	885	1040	1190	1320	1445	1620	1815	2005
4.4	Lift Height		h3 mm	4365	4825	5280	5740	6120	6400	6930	7490	8075
4.5	Extended Height	w.o. load backrest	h4 mm	4875	5335	5790	6250	6630	6910	7440	8000	8585
	Extended Height	with load backrest	h4 mm	5585	6045	6500	6960	7340	7620	8150	8710	9295

* 5/3 with front panel (Windshield)

** Not available in combination with cab options on the SCT only

Table 2 – Mast Chart SC 6000 1.8/2.0

					TL Mast							
					SC 6040 SC 6060							SC 6040 SCF 6060
4.1	Tilt	forward/backward		°	5/5	5/5	5/5	5/3	5/3	5/3	5/3	5/3
4.2	Collapsed Height		h1	mm	1955	2105	2260	2410	2540	2665	2840	3035
4.3	Free Lift		h2	mm	150	150	150	150	150	150	150	150
4.4	Lift Height		h3	mm	2895	3200	3505	3810	4060	4190	4545	4925
4.5	Extended Height	w.o. load backrest	h4	mm	3480	3785	4090	4395	4650	4780	5135	5515
	Extended Height	with load backrest	h4	mm	4115	4420	4725	5030	5285	5415	5770	6150

					TF Mast		Quad
					SC 6040 SC 6060		SC 6040 SCF 6060
4.1	Tilt	forward / backward		°	5/5*	5/5*	5/3**
4.2	Collapsed Height		h1	mm	1955	2105	2105
4.3	Free Lift	without load backrest	h2	mm	1345	1495	1500
		with load backrest	h2	mm	735	885	885
4.4	Lift Height		h3	mm	2895	3200	6095
4.5	Extended Height	w.o. load backrest	h4	mm	3510	3810	6635
	Extended Height	with load backrest	h4	mm	4115	4420	7315

* 5/3 with front panel (Windshield)

** Not available on SCT 6060-2.0, SCF 6060-2.0

					TT Mast							
					SC 6040 SC 6060					SC 6040 SC 6060	SC 6040 SCF 6060	
4.1	Tilt	forward / backward		°	5/5	5/5	5/5	5/3	5/3	5/3	5/3	5/3
4.2	Collapsed Height		h1	mm	1955	2105	2260	2410	2540	2665	2840	3035
4.3	Free Lift	without load backrest	h2	mm	1445	1600	1750	1905	2030	2155	2335	2540
		with load backrest	h2	mm	735	885	1040	1190	1320	1445	1625	1825
4.4	Lift Height		h3	mm	4365	4825	5280	5740	6120	6400	6930	7490
4.5	Extended Height	w.o. load backrest	h4	mm	4880	5335	5795	6250	6630	6910	7445	8005
	Extended Height	with load backrest	h4	mm	5590	6050	6510	6960	7345	7620	8155	8715

Table 3 – Working Aisle Width

	1.9	1.8	4.35	Pallets length x width	4.33		
	Wheelbase	Load Distance	Turning Radius		Aisle Width according to VDI 2198		
	Y	X	Wa		w.o. sideshift	integrated sideshift	with hook-on sideshift
SCT 6010 1.3	1174	-	1390	800 x 1200	2857	2889	2909
		316		1200 x 800	3158	3193	3215
		352,2		1000 x 1200	3036	3069	3090
		375		1200 x 1000	3186	3221	3242
SCT 6020 1.3 SCT 6020 1.6	1282	-	1493	800 x 1200	2960	2992	3012
		316		1200 x 800	3261	3296	3318
		352,2		1000 x 1200	3139	3172	3193
		375		1200 x 1000	3289	3324	3345
SCT 6040 1.6	1390	-	1597	800 x 1200	3064	3096	3116
		316		1200 x 800	3365	3400	3422
		352,2		1000 x 1200	3243	3276	3297
		375		1200 x 1000	3393	3428	3449
SCT 6040 1.8	1390	-	1597	800 x 1200	3108	3141	3161
		366		1200 x 800	3413	3448	3471
		402,2		1000 x 1200	3289	3322	3343
		425		1200 x 1000	3441	3475	3497
SCT 6060 1.8 SCT 6060 2.0	1498	-	1704	800 x 1200	3215	3248	3268
		366		1200 x 800	3520	3555	3578
		402,2		1000 x 1200	3396	3429	3450
		425		1200 x 1000	3548	3582	3604

SCF 6040 1.6	1439	-	1709	800 x 1200	3176	3208	3228
		316		1200 x 800	3477	3512	3534
		352,2		1000 x 1200	3355	3388	3409
		375		1200 x 1000	3505	3540	3561
SCF 6040 1.8	1439	-	1709	800 x 1200	3220	3253	3273
		366		1200 x 800	3525	3560	3583
		402,2		1000 x 1200	3401	3434	3455
		425		1200 x 1000	3553	3587	3609
SCF 6060 1.8 SCF 6060 2.0	1547	-	1816	800 x 1200	3327	3360	3380
		366		1200 x 800	3632	3667	3690
		402,2		1000 x 1200	3508	3541	3562
		425		1200 x 1000	3660	3694	3716

Standard Equipment

1. Crown's Access 1 2 3® Comprehensive System Control
2. InfoPoint™ System
3. Crown-manufactured AC drive and AC lift motors
4. e-GEN® Braking System with automatic parking brake
5. Adjustable D4 armrest, forward/backwards with
 - Fingertip control levers
6. Thumb operated travel direction switch integrated in armrest
7. Intrinsic Stability System
 - Travel speed reduction and appropriate electronic brake control when forks are above free lift
 - Forward tilt interlock reduces forward tilt above freelifit to maximise stability
 - Controlled tilt speeds
 - Counterweight exceeds required standards
 - Cornering speed control
 - Ramp hold
 - Ramp speed control
8. Driveability standard features
 - 375 mm step height
 - Large, unobstructed floorboard
 - Non-slip rubber floor mat
 - Automotive type rubber covered accelerator and brake pedals
 - Automatic parking brake (seat activated)
 - Large, entry/exit "window"
 - Entry/exit to both sides
 - Rounded edges on battery cover for easy entry/exit
 - Comfort suspension safety seat MSG 65 vinyl with hip restraint
 - High visibility orange anti-cinch safety belt
 - magnetic orange storage tray on seatdeck
 - Compact steering column and small steering wheel
 - Spinner knob with grips
 - Infinitely adjustable tilt steering column
 - Operator-forward design for enhanced visibility
 - Low dashboard for fork and floor visibility
9. Crown display
 - Battery discharge indicator with lift interrupt and re-key feature
 - Hour meters / travel distance / stop watch
 - Pin code access capable
 - Event code display with five (5) key navigation
 - Access 1 2 3 diagnostics
 - P1, P2, P3 Performance tuning

10. 48 volt system
11. SBE 320 blue battery connector
12. DIN 43531 battery compartment sizes
 - Side extraction battery access
 - Battery retainer switch inhibits travel when battery is not securely locked
13. Two 15" Super Elastic steer tyres
14. Large 18" Super Elastic drive tyres
15. SIT Tyres, one piece rim without taper, rim flange or locking ring
16. On-demand power steering
17. Cab-ready overhead guard design
18. 2105 mm overhead guard height
19. No tool lift out floorboards for service access
20. High visibility mast with in-line hose routing
21. Smooth lift and lower transition through mast staging
22. O-ring face seal hydraulic fittings
23. Tilting mast
24. Tow pin
25. Entry/exit grab handle

Optional Equipment

1. TL, TF, TT and Quad mast styles
2. Choice of hydraulic control levers
 - Adjustable Crown D4 Armrest with:
 - Dual lever hydraulic controls
 - Mini lever hydraulic controls
 - Combination of dual and mini lever controls
 - Manual levers, urethane covered offset positioned control handles with tactile feedback
3. Directional controls
 - Dual pedal
 - Foot operated directional control
 - Lever in Crown D4 Armrest (only available for mini, dual or combination hydraulic controls)
 - Lever integrated in steer column, left or right side
 - Switch integrated in manual hydraulic lift lever
4. Battery rollers for side extraction
5. Hinged and lockable battery door
6. Battery transfer system BTS for fast and safe battery exchange

7. DIN A 160 Battery Connector
8. Tilt Position Assist TPA
 - Mast tilt stops in vertical position
9. Auxiliary mast hydraulics
 - single function
 - double function, with 4 spool valve and accessory plumbing
10. Single or double quick disconnect hydraulic connectors
11. Hook-on or integrated sideshifter
12. Hook-on fork positioner
13. Various load backrest heights
14. Various fork lengths
15. Choice of tyres
 - Non-marking Super Elastic tyres
 - Lugged cushion tyres (SCT 6000 only)
16. Rear mud flaps for SCF 6000
17. Suspension seat fabric
18. Freezer conditioning
19. Low overhead guard, 1990 mm high
20. Drive-In racking OHG
21. Plexiglass roof panel
22. Light packages
 - Interior dome light
 - Work lights
 - Flashing lights
 - Integrated brake, tail and back-up light
 - LED Travel light package
 - o Headlights
 - o Dipped / low beam
 - o Turn / indicator lights
 - o Hazard flashing lights
 - o Tail lights at lower rear
23. InfoLink Ready
24. 48 Volt accessory cable
25. Audible travel alarm
26. Floor spotlight, blue
27. Sunshade
28. Rear view mirror
29. Work Assist™ Accessories
 - Clip pad and hook
 - Clamp
 - Clamp and mounting plate
 - Various storage pocket
 - Storage bin (magnetic mount)
30. 5th Function
31. Quick Charge Options
32. Crown V-force Lithium ready
33. Top panel wire mesh

Cabin Features

1. Partial Cab
 - Front screen with tempered glass, wiper and washer
 - Top screen with laminated safety glass
 - Cabin height as on standard overhead guard height
 - Rear screen with tempered glass, defrost with 15 minute auto off timer, wiper and washer,

- gas spring assist 2-stage tilting window
2. Soft Cab
 - Full cabin with soft doors
 - PVC zipper type roll-up doors with large windows.
 3. Full Cab
 - Cabin with hard doors with automotive-class comfort. Removable hard doors with gas spring and door locks, two-way sliding windows on both sides, side windows with tempered glass.
 4. Heater for full cabins.
 - Lower right side mounted cabin heater with temperature control and 2-speed fan.
 - Five adjustable outlets: foot, operator, defrost.

Driveability

The SC 6000 Series incorporates numerous design features to improve operator comfort and productivity. On-demand power steering is served by the main hydraulic pump when steering is requested. Steering system with equal area and double-acting cylinder provides an equally responsive steering rate both ways.

A large step positioned at a low height of only 375 mm aids entry/exit on both sides of the truck. The narrow, offset tilt steer column and steer wheel further facilitate entry/exit. Floorboards are large, unobstructed and rubber covered to insulate the operator from vibration. Brake and accelerator pedals are rubber covered to provide good grip and comfort.

Several designs contribute to better visibility everywhere you look. A low dashboard for fork visibility, a slim overhead guard with upper unobstructed window for load handling at height, a high visibility mast and a compact steer column all improve operator visibility around the truck.

Hydraulic controls allow easy blending of up to 4 hydraulic functions. Fingertip controls are integrated into the adjustable armrest. Dual-Axis controls are recommended when operators wear gloves. The manual levers are urethane covered with tactile feedback for comfort and easy selection. Control actuation forces are minimal and responsive.

Crown Drive System

Crown has applied the latest generation AC drive system, enhanced with Access 1 2 3 technology. The demand for high efficiency systems that closely match customer torque requirements is met with this latest generation control system. Crown-manufactured, independently controlled, AC drive motors are specifically designed to optimise system integration between the traction and braking controls.

Crown's Access 1 2 3 technology provides optimum performance and control by offering a communication interface for operators and technicians, intelligent coordination of lift truck system and simplified service with advanced diagnostics.

The Crown display is used for easy troubleshooting, access service history and set performance features. Three modes of performance can be selected to accommodate operator experience or application requirements.

e-GEN® Braking System

Variable regenerative motor braking is optimised and assisted with electric friction brakes, eliminating maintenance associated with typical wet, disk or drum style brakes. The appropriate amount of stopping force is applied to match operator brake input and the current operating conditions of the truck.

The closed loop Access 1 2 3 traction control will auto-matically keep the truck on hold until a travel input is requested, even when operating on a ramp.

Automatic electric parking brakes activate when the operator leaves the seat, a travel input has not been requested or battery power has been disconnected.

Three wheel truck with Proportional Rack and Pinion Steering System

The hydrostatic power steering uses a large, totally enclosed rack and pinion gear assembly. Debris guard prevent stretchfoils and other materials from being picked up and wrapped around the axle.

Four wheel truck

The rugged axle frame, forged spindle and connecting links eliminate the need for adjustment. A two-piece spindle and kingpin with tapered roller bearings improves life and serviceability. Spherical bearings with straight pins in the connecting links eliminate any play in the linkage. All bearing locations are sealed to exclude contaminants and are equipped with lubrication fittings for ease of service.

The steering geometry is matched to the controller to deliver smooth steering at all angles. The advantage is less tyre scrubbing which extends tyre life. Both motors receive power, even in the tightest turns. This helps the truck to accelerate, turn and manoeuvre even from a full turn start position. Cornering speed control regulates the drive motor's output by the turning degree of the truck. The advantage is smooth, stable steering which may increase operator confidence and productivity.

Hydraulics

Low noise hydraulic pump serves both lift and steer systems. The hydraulic system provides continuous filtration through suction filter and easy to service return filter. Hydraulic actuation is precise and oil is controlled using metered spool valves. 3 spool valve for lift/lower, tilt and an auxiliary function is standard and features an integrated pressure relief valve for system protection. A pressure compensation lowering valve ensures safe controlled lowering speeds.

Ram displacement type lift cylinders and two double acting tilt cylinders are Crown-manufactured and designed for long life. All rams and piston rods are hard chrome plated to reduce pitting corrosion and extend cylinder packing life. O-ring face seal fittings are used to eliminate leaks.

Mast Assembly

Crown-manufactured three-stage mast assembly utilises a "flush-face" interlocked I-beam design to improve visibility and reduce truck length. Roller bearing studs are welded on both sides of the rails for maximum strength and roller bearings are canted to run in the thick cross section of the rail. High strength steel mast sections with sealed-for-life rollers are constructed for low mast deflection and high rigidity. Tie bars wrap around the rails for added strength and to resist off-centre load forces.

"In-line" hose routing opens up visibility. Cylinders are placed behind the rails to create a high visibility design. The mast has four points of attachment to the truck for good load force distribution. Two mounting points are at the frame, where tilt cylinders attach. Tilt cylinders use spherical bushings to resist off-centre load distortions.

Two large diameter axles secure the mast to the drive units.

The Crown manufactured mast offers quiet lift transition through staging while lifting and lowering. Ante rattle devices reduce mast noise when traveling on uneven surfaces.

A range of mast types are available:

- TL offers maximum visibility through the mast by eliminating the inner free lift cylinder.
- TF offers widest visibility window with full free lift capability.
- TT offers maximum flexibility with full free lift capability.
- The Quad mast offers maximum lift height at lowest collapsed height.

Drive Units

Two independent drive units are manufactured by Crown. The heavy duty drive unit gears are constantly lubricated in an oil bath. This time proven design is quiet and reliable, providing years of trouble-free service.

Carriage

An FEM / ISO / ITA Class II carriage is standard. Fork spread is adjustable between 314 – 914 mm. There is a choice of a Crown manufactured integrated sideshifter or hook-on ISO type sideshifter. Other attachments such as a fork positioner are easy to add. Crown manufactured forged high strength steel forks with fork tip indicators are available in various lengths.

Battery Access

Seat deck with latch can be easily lifted for excellent battery access. Seat deck is supported by gas struts and stays vertically. A lift out battery door is standard. A battery retainer switch prevents unintentional operation, when battery door is not properly fitted. A hinged battery door is an option. Crown V-force Litium ready option comes with full side cover with an access cutout for lateral charging.

Battery Transfer System BTS

The patent pending BTS system is optionally available. This unique manually powered system allows fastest and safest battery exchange within minutes for extended operating hours or continuous truck operation by exchanging spare batteries.

Safety Regulations

Conforms to European safety standards. Dimensions and performance data given may vary due to manufacturing tolerances. Performance is based on an average size vehicle and is affected by weight, condition of truck, how it is equipped and the conditions of the operating area. Crown products and specifications are subject to change without notice.

European Manufacturing:
Crown Gabelstapler GmbH & Co. KG
Roding, Germany
www.crown.com

